



evak  
PUMP PARTNERS



60HZ  
**RHINO**

Vertical Multi-stage  
Centrifugal Pump

EVAK PUMP TECHNOLOGY CORP.

[www.evak-pumps.com](http://www.evak-pumps.com)

E-MAIL : [sales@evak-pumps.com](mailto:sales@evak-pumps.com)

TEL +886-4-26233556

FAX +886-4-26235559





# CONTENTS

## INTRODUCE

- 03 About EVAK
- 05 Smart Manufacturing
- 07 Quality Management

## PRODUCTS

- |    |              |    |          |
|----|--------------|----|----------|
| 09 | RHINO SERIES | 16 | RHINO 20 |
| 11 | RHINO 1      | 17 | RHINO 32 |
| 12 | RHINO 3      | 18 | RHINO 45 |
| 13 | RHINO 5      | 19 | RHINO 65 |
| 14 | RHINO 10     | 20 | RHINO 90 |
| 15 | RHINO 15     |    |          |



# PUMP PARTNERS

WITH THE EXPERIENCE AT THE HELM



# About EVAK

EVAK, originating from Taiwan, specializes in the sales of submersible and sewage pumps, as well as IoT intelligent pressure control equipment. Our products are sold in over 60 countries worldwide. Through our comprehensive services, we provide complete water solutions and localized support to our global customers, making EVAK their most trusted pump partners.



**E<sup>3</sup>**

## Efficiency

EVAK's R&D team is dedicated to design and technological innovation with a forward-looking vision, creating high-efficiency and reliable pump products and solutions.

## Energy Saving

Our pumps boast high energy conversion efficiency, playing a key role in creating a sustainable environment.

## E-Intelligence

EVAK understands that intelligent solutions are the trend in market services. By leveraging APP and AI technology, we enhance intelligent market services, creating a new paradigm distinct from traditional operations.



# Smart Factory

Pioneering in smart manufacturing, we embrace innovation to unveil a world fully managed by robotic systems.

The EVAK factory spans 150 acres with an annual production capacity of 500,000 units/sets of pumps.



## 100% Automated Production

- Impeller Housing Automatic Stamping Unit
- Robot Stamping Unit
- High Precision Mold Stamping Unit
- AGV Transportation Cleaning Unit
- Stacking Unit

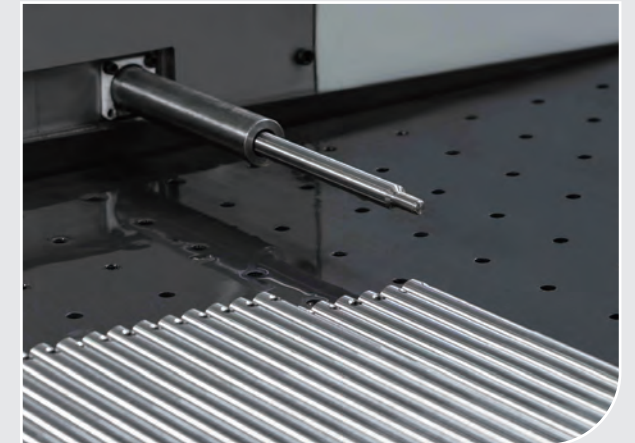

## High- Precision Welding

- Guide Vane Laser Welding Center
- Impeller Housing Automatic Stamping Line







**Welding**



**Stamping**



## Ultra-precision Machining

- Water Processing Unit
- Pump Shaft Processing Unit
- Pressure Resistant Cylinder Processing Unit

## Strict Production Testing

- Raw Material And Component Quality Control
- Parts Pressure Holding Test:

## Efficient Assembly

- Rotating Elements Automatic Assembly
- Assembly And Testing Units

## Quality Management System

- Noise and Operation Check: A standard silent room is used to test for noise and operational irregularities.
- Automated Testing: The water pump assembly test is automated, and the finished product test is conducted in a quiet environment
- Comprehensive Testing: All completed EVAK water pumps undergo 100% testing for water flow, flow rate, head, efficiency, vibration, and noise to guarantee high-quality performance.
- Traceability: The barcode on the water pump can be traced back to the factory report.





# RHINO SERIES

## Features

The RHINO Pump is a multi-functional pump that can transport liquids of different types from the water source to the factory. It is suitable for a wide range of temperatures, flow rates, and pressure ranges.



### General Water Supply

Filtration and Conveyance of Tap Water, Zoned Water Supply, Main Pipeline Boosting, Boosting for High-rise Buildings.

### Altitude: Maximum 1,000 meters

Reverse Osmosis Systems, Distillation Systems, Swimming Pools.

### Industrial Water Boosting

Cleaning Systems, High-pressure Rinsing Systems, Fire Fighting System Boosting.

### Agricultural Irrigation

Water for field irrigation, water for sprinkler irrigation, water for drip irrigation.

### Industrial Liquid Transport

Cooling and Air Conditioning Systems, Boiler Feedwater and Condensate Systems, Machine Tool Coolants.



# PERFORMANCE CURVE

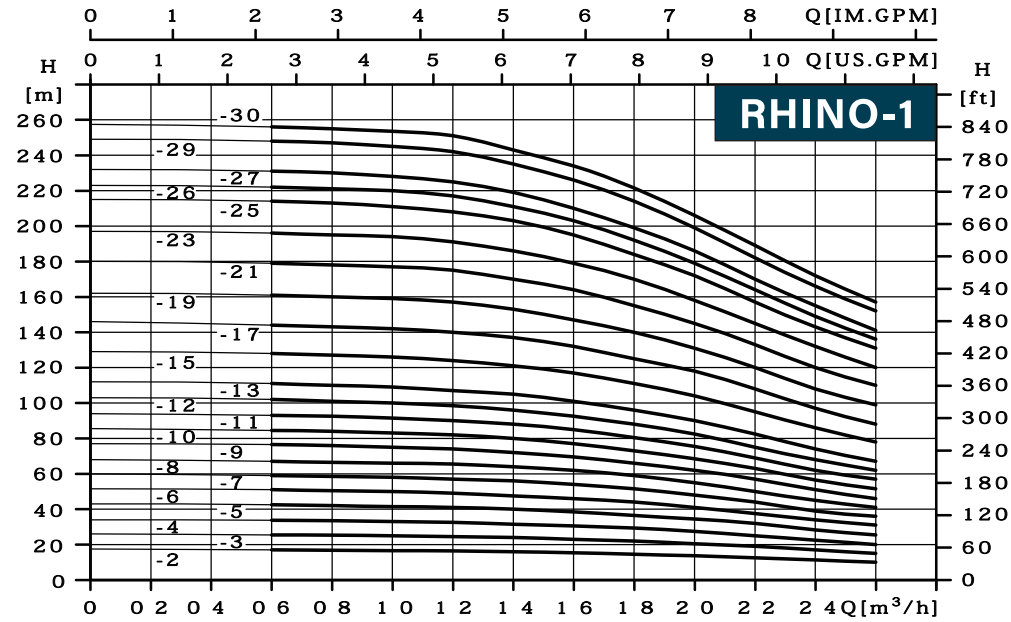

# DATA CHART

Model	Driving motor (kW)	Q (M³/H)	0.6	0.8	1	1.2	1.4	1.6	1.8	2	2.4	2.6
RHINO 1-2	0.37		17.5	17	16.8	16.4	16	15.4	14.5	13.7	11.3	10
RHINO 1-3	0.37		26	25.5	25.3	24.5	24	23	22	20.5	17	15
RHINO 1-4	0.37		34	33.8	33.5	32.5	31.5	30.5	29.3	27.5	22.5	20
RHINO 1-5	0.55		43	42.5	42	41	40	38.5	36.5	34.4	28.3	25.5
RHINO 1-6	0.55		51.5	51	50.5	49	47.5	46	44	41	34	31
RHINO 1-7	0.75		60	59	58.5	57	56	54	51.5	48	39	36
RHINO 1-8	0.75		68	67	66.5	65.5	64	62	59	55	45	41
RHINO 1-9	0.75		77	76.5	76	74	72	69.5	66	62	51	46
RHINO 1-10	1.1		85.5	84.5	84	82	80	77	73	68.5	56.5	51.5
RHINO 1-11	1.1		94	93	92.5	90	88	85	80.5	75.5	62	57
RHINO 1-12	1.1		103	102	101	98.5	96	92.5	88	82.5	68	62
RHINO 1-13	1.1		112	111	110	107	105	101	96	90	74	67
RHINO 1-15	1.5		129	128	127	124	121	117	111	104	86	78
RHINO 1-17	1.5		146	144	143	140	137	132	125	118	97	88
RHINO 1-19	2.2		162	161	160	157	153	147	140	131	108	99
RHINO 1-21	2.2		180	179	178	175	170	164	155	145	120	110
RHINO 1-23	2.2		197	196	195	191	186	179	170	158	132	120
RHINO 1-25	2.2		215	214	213	208	203	195	184	172	143	131
RHINO 1-26	2.2		223	222	221	217	211	203	192	179	149	136
RHINO 1-27	3		232	231	230	225	219	210	199	186	155	141
RHINO 1-29	3		249	248	247	242	235	226	214	199	166	152
RHINO 1-30	3		257.5	256	255	251	243	234	221.5	206	172	157

# DIMENSION

RHINO 1-19~1-30 sub-connection of pipeline has no oval flange connection. The overall dimensions of the single-phase motor and explosion-proof motor are a little different. Pls contact us for details.

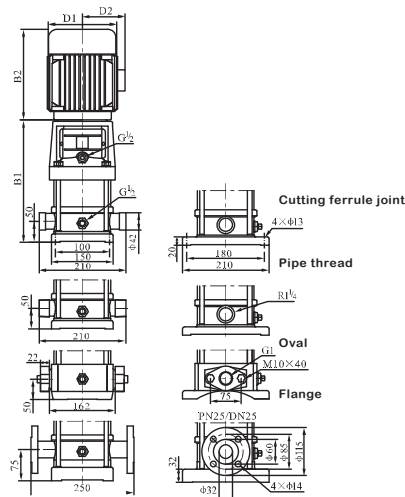

# INSTALLATION

Model	Size(mm)					Weight (kg)
	B1	B2	B1+B2	D1	D2	
RHINO 1-2	261	220	481	138	103	23
RHINO 1-3	279	220	499	138	103	23
RHINO 1-4	297	220	517	138	103	24
RHINO 1-5	315	220	535	138	103	25
RHINO 1-6	333	220	553	138	103	25
RHINO 1-7	361	248	627	148	108	29
RHINO 1-8	379	248	645	148	108	29
RHINO 1-9	397	248	663	148	108	30
RHINO 1-10	415	248	681	148	108	33
RHINO 1-11	433	248	699	148	108	33
RHINO 1-12	451	248	717	148	108	34
RHINO 1-13	469	248	807	148	108	34
RHINO 1-15	515	292	825	171	119	39
RHINO 1-17	533	292	843	171	119	39
RHINO 1-19	551	292	861	171	119	41
RHINO 1-21	569	292	897	171	119	42
RHINO 1-23	605	292	915	171	119	45
RHINO 1-25	623	292	933	171	119	46
RHINO 1-26	641	292	1012	171	119	56
RHINO 1-27	705	343	1048	196	131	58
RHINO 1-29	723	343	1066	196	131	59
RHINO 1-30	669	343	609	196	131	44

# PERFORMANCE CURVE

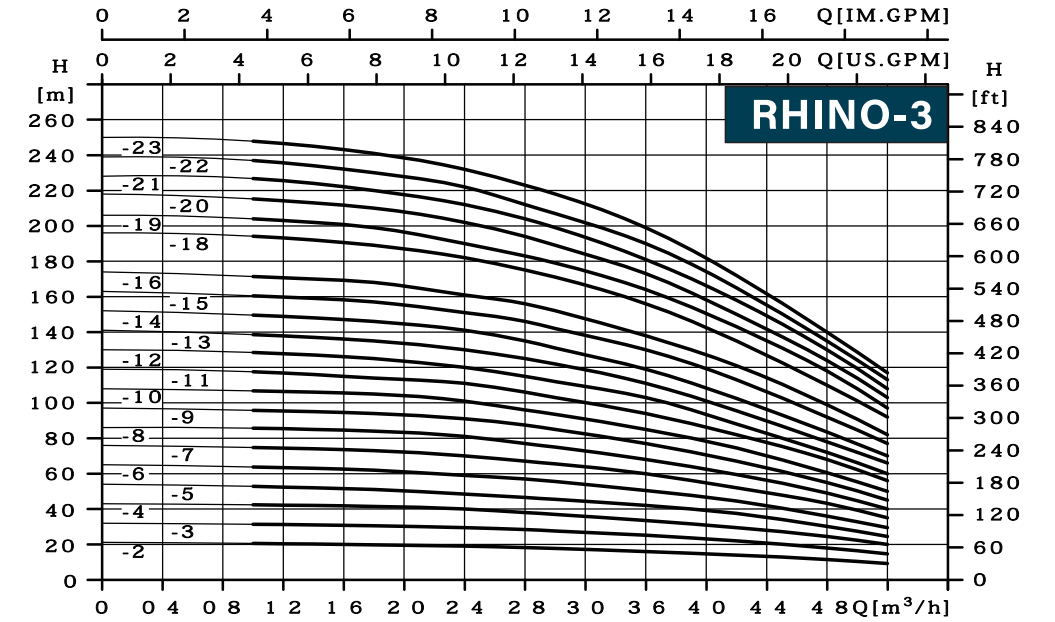

# DATA CHART

Model	Driving motor (kW)	Q (M³/H)	0	1.4	1.8	2.4	2.8	3	3.6	4.2	4.8	5.2
RHINO 3-2	0.37		21.2	20.2	19.8	19	18.2	17.7	16	14	11.5	9.2
RHINO 3-3	0.55		32	31	30.5	29.5	28.4	27.6	25.2	22	18	14.6
RHINO 3-4	0.75		43	42	41.5	40	38	37	33.5	29.5	24.5	20
RHINO 3-5	1.1		54	63	51	48.5	46.5	45.5	42	37.5	30.2	24.5
RHINO 3-6	1.1		65	74	62	59	57	55.5	50.5	44.5	36	29.5
RHINO 3-7	1.1		76	85	73	70	67	65.5	60	52	43.2	35
RHINO 3-8	1.5		86	95	84	81	77	75	68	59.5	49	40
RHINO 3-9	1.5		97	106	94	91	87.5	85	77	67	55	45
RHINO 3-10	2.2		108	116	105	101	96	93.5	85	74.5	60.5	50
RHINO 3-11	2.2		119	127	114	111	106	103	94	88	68	56
RHINO 3-12	2.2		130	137	125	120	115	112	103	95.5	72	60
RHINO 3-13	2.2		141	148	135	130	125	122	111	102.5	78	66
RHINO 3-14	2.2		152	159	146	151	135	131	119	113	83.5	70
RHINO 3-15	3		163	170	157	161	146	142	130	121	92	77
RHINO 3-16	3		174	192	168	182	156	152	138	135	99	82
RHINO 3-18	3		196	202	189	190	175	171	156	143	110	97
RHINO 3-19	4		206	213	199	202	183	179	164	150	118	103
RHINO 3-20	4		218	224	210	212	194	189	173	158	124	108
RHINO 3-21	4		228	234	220	222	204	199	181	165	130	113
RHINO 3-22	3		239	245	230	232	212	207	190	172	135	117
RHINO 3-23	4		250	52	241	141	223	218	199	82	140	92

# DIMENSION

RHINO 3-15~3-23 sub-connection of pipeline has no oval flange connection. The overall dimensions of the single-phase motor and explosion-proof motor are a little different. Pls contact us for details.

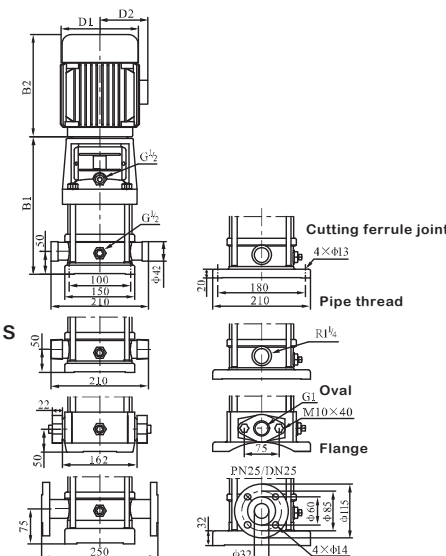

# INSTALLATION

Model	Size(mm)					Weight (kg)
	B1	B2	B1+B2	D1	D2	
RHINO 3-2	261	220	481	138	103	23
RHINO 3-3	279	220	499	138	103	24
RHINO 3-4	307	248	555	148	108	29
RHINO 3-5	325	248	573	148	108	30
RHINO 3-6	343	248	591	148	108	30
RHINO 3-7	361	248	609	148	108	31
RHINO 3-8	389	292	681	171	119	38
RHINO 3-9	407	292	699	171	119	38
RHINO 3-10	425	292	717	171	119	41
RHINO 3-11	443	292	735	171	119	41
RHINO 3-12	461	292	753	171	119	42
RHINO 3-13	479	292	771	171	119	42
RHINO 3-14	497	292	789	171	119	50
RHINO 3-15	525	343	868	196	131	51
RHINO 3-16	43	343	886	196	131	51
RHINO 3-18	561	343	904	196	131	52
RHINO 3-19	579	343	922	196	131	58
RHINO 3-20	597	348	945	215	150	58
RHINO 3-21	615	348	963	215	150	59
RHINO 3-22	633	348	981	215	150	59
RHINO 3-23	651	348	999	215	150	43



# PERFORMANCE CURVE

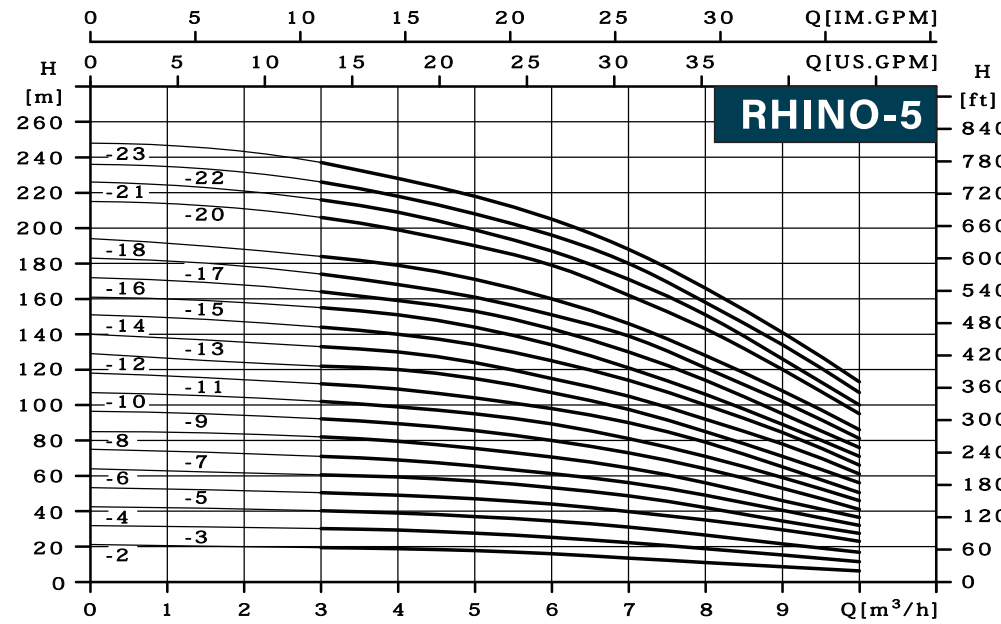

# DATA CHART

Model	Driving motor (kW)	Q (M³/H)	0	3	4	5	6	7	8	9	10
RHINO 5-2	0.55	H (m)	21.2	19.4	18.8	17.7	16	13.5	11	8.6	6.2
RHINO 5-3	0.75		31.8	30.2	29.3	27.6	25.2	22.3	18.8	15.2	11.5
RHINO 5-4	1.1		42.5	40.3	39	37	34.5	31	26.5	21.5	16.8
RHINO 5-5	1.5		53.3	50.4	49	47	44	39.8	35	29.5	23
RHINO 5-6	1.5		64	60.5	59.3	57	53.3	48.7	42	34.5	27.5
RHINO 5-7	2.2		75	71	69	65.5	61.2	56.2	49	40.5	32
RHINO 5-8	2.2		85	82	79.5	75.5	70.6	64.5	56	46	36.5
RHINO 5-9	2.2		96.5	92.2	89.5	85.5	80	73	64	53	41
RHINO 5-10	3		107	102	99	95	89.3	81	71	59	46
RHINO 5-11	3		118	112	109	104	98	90	79	65	50.5
RHINO 5-12	3		129	122	120	115	107	97.5	85	71	56
RHINO 5-13	4		140	133	130	124	115	105	92	78	61
RHINO 5-14	4		151	144	140	134	125	114	100	84.5	66
RHINO 5-15	4		161	155	151	144	134	121	106	89	71
RHINO 5-16	4		172	164	159	153	143	130	114	95	76
RHINO 5-17	5.5		183	174	168	161	151	139	121	102	81
RHINO 5-18	5.5		194	184	179	171	160	146	128	108	86
RHINO 5-20	5.5		215	206	199	190	179	162	143	120	95
RHINO 5-21	5.5		226	216	209	199	187	171	151	126	100
RHINO 5-22	5.5		236	226	218	208	196	180	158	134	107
RHINO 5-23	5.5		248	237	228	218	205	188	166	141	113

# PERFORMANCE CURVE

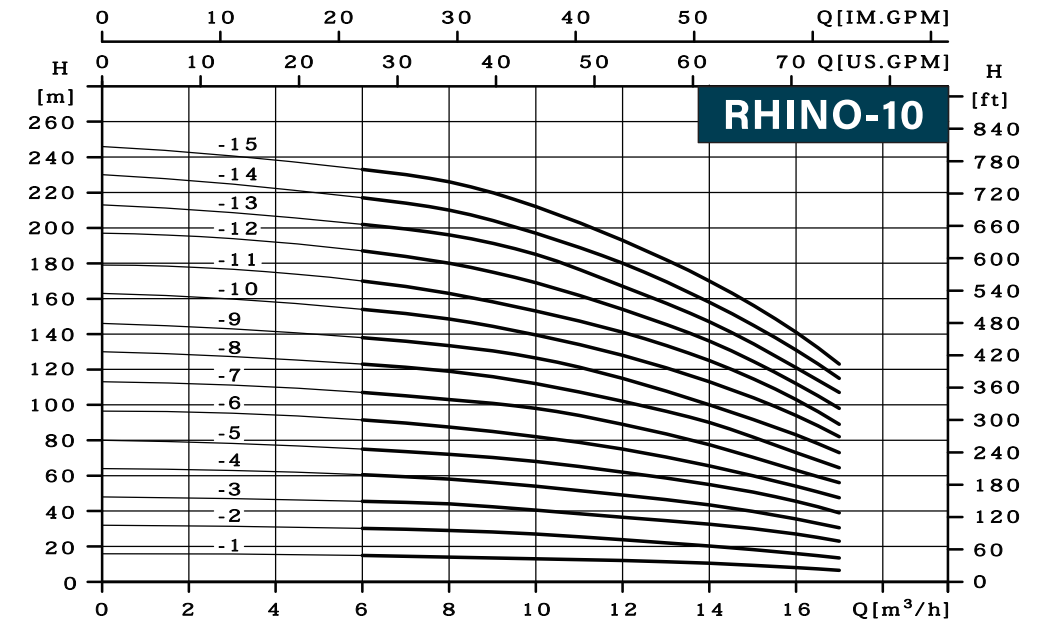

# DATA CHART

Model	Driving motor (kW)	Q (M³/H)	0	6	8	10	12	14	16	17
RHINO 10-1	0.75	H (m)	15.8	14.9	14	13	12	10.5	8	6.5
RHINO 10-2	1.5		32	30.2	29	27	23.8	20.2	16	13.5
RHINO 10-3	2.2		48	45.5	44	40.5	36.5	32.5	27	23
RHINO 10-4	3		64	60.5	58	54	49	43.5	35.5	30.5
RHINO 10-5	4		80	75	72	68	62	55	45.5	39
RHINO 10-6	4		96.5	91.5	87.5	82	75	65.5	54	47.5
RHINO 10-7	5.5		113	107	103	98	89	77.5	63	56
RHINO 10-8	5.5		130	123	119	112	102	90	73	64.5
RHINO 10-9	7.5		146	138	133.5	126.5	115	100	83	73
RHINO 10-10	7.5		163	154	148.5	139.5	128	113	94	82
RHINO 10-11	7.5		179	170	163	153	141	125	103	89
RHINO 10-12	7.5		197	187	180	169	154	136	112	98
RHINO 10-13	11		213	202	196	185	167	147	121	107
RHINO 10-14	11		230	217	210	197	180	158	131	115
RHINO 10-15	11		24	233	226	212	193	170	141	123

# DIMENSION

RHINO 5-21~5-31 sub-connection of pipeline has no oval flange connection. The overall dimensions of the single-phase motor and explosion-proof motor are a little different. Pls contact us for details.

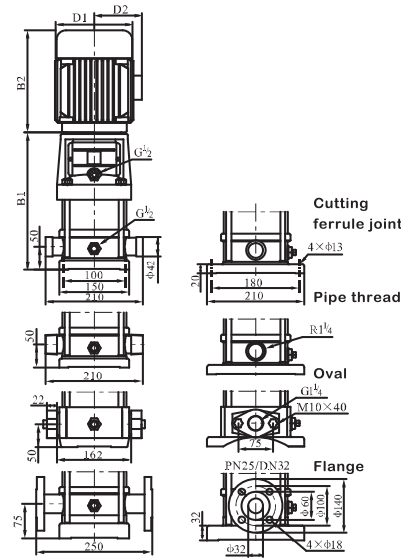

# INSTALLATION

Model	Size(mm)					Weight (kg)
	B1	B2	B1+B2	D1	D2	
RHINO5-2	276	225	501	148	117	22
RHINO5-3	303	225	528	148	117	24
RHINO5-4	330	225	555	148	117	25
RHINO5-5	367	245	612	170	142	28
RHINO5-6	394	245	639	170	142	30
RHINO5-7	421	245	666	170	142	30
RHINO5-8	448	245	693	170	142	31
RHINO5-9	485	290	775	190	155	36
RHINO5-10	512	290	802	190	155	36
RHINO5-11	539	290	829	190	155	37
RHINO5-12	566	290	856	190	155	41
RHINO5-13	593	290	883	190	155	41
RHINO5-14	620	290	910	190	155	42
RHINO5-15	647	290	937	190	155	42
RHINO5-16	674	290	964	190	155	43
RHINO5-17	711	345	1056	197	165	51
RHINO5-18	738	345	1083	197	165	51
RHINO5-20	792	345	1137	197	165	52
RHINO5-21	819	345	1164	197	165	52
RHINO5-22	846	355	1201	230	188	59
RHINO5-23	873	355	1228	230	188	59
RHINO5-24	900	355	1255	230	188	60
RHINO5-25	927	355	1282	230	188	60
RHINO5-27	954	355	1309	230	188	61
RHINO5-28	981	390	1336	230	188	61
RHINO5-29	1028	390	1418	260	208	83
RHINO5-30	1055	390	1445	260	208	83
RHINO5-33	1082	390	1472	260	208	84

# DIMENSION

RHINO 10-15~10-22 sub-connection of pipeline has no oval flange connection. The overall dimensions of the single-phase motor and explosion-proof motor are a little different. Pls contact us for details.

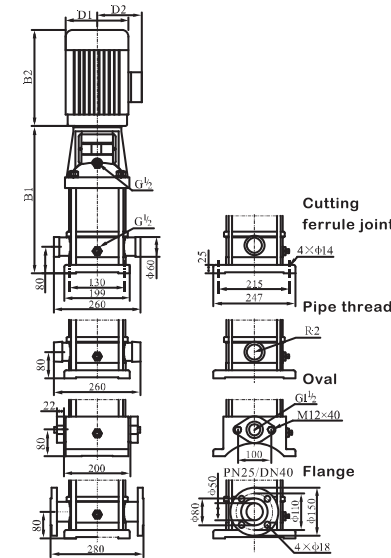

# INSTALLATION

Model	Size(mm)					Weight (kg)
	B1	B2	B1+B2	D1	D2	
RHINO 10-1	350	248	598	148	108	40
RHINO 10-2	390	292	682	171	119	47
RHINO 10-3	420	292	712	171	119	51
RHINO 10-4	460	343	803	196	131	61
RHINO 10-5	490	348	838	215	150	69
RHINO 10-6	520	348	868	215	150	69
RHINO 10-7	628	383	1011	257	167	81
RHINO 10-8	658	383	1041	257	167	81
RHINO 10-9	688	383	1071	257	167	86
RHINO 10-10	718	383	1101	257	167	86
RHINO 10-11	748	383	1131	257	167	87
RHINO 10-12	778	383	1161	257	167	88
RHINO 10-13	838	499	1337	314	258	153
RHINO 10-14	868	499	1367	314	258	154
RHINO 10-15	898	499	1397	314	258	155



## PERFORMANCE CURVE

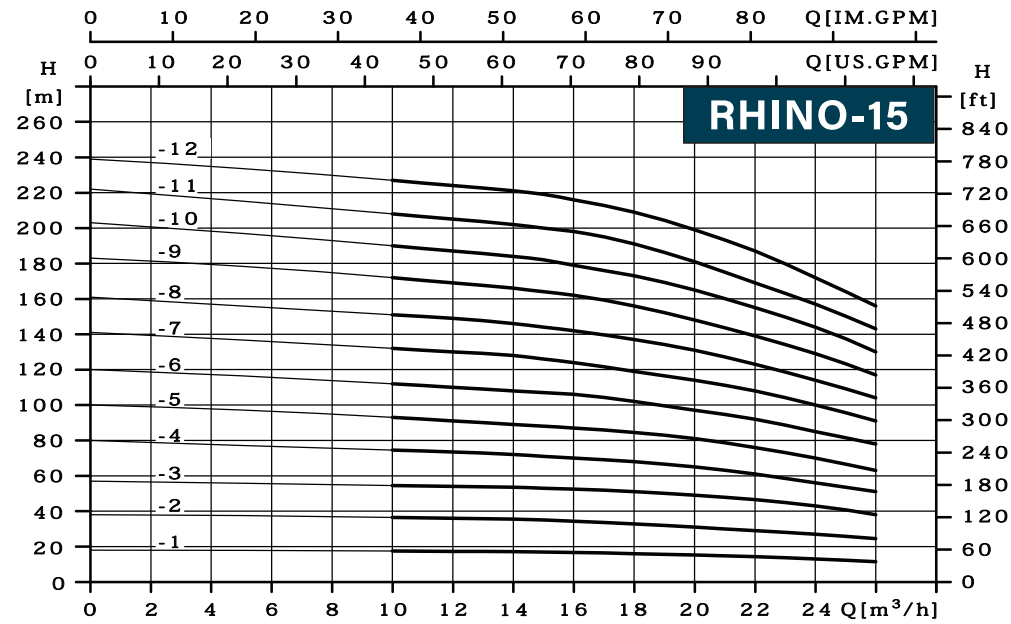

## DATA CHART

Model	Driving motor (kW)	Q (M³/H)	H (m)											
			0	10	12	14	15	16	18	20	22	24	26	
RHINO 15-1	1.5		18	17.5	17.3	17.1	16.9	16.7	16	15.2	14.3	13	11.5	
RHINO 15-2	3		38	36.5	36	35.5	35	34.3	32.8	31	29	27	24.5	
RHINO 15-3	4		57	54.5	54	53.5	53	52.5	51	49	46.5	43	38	
RHINO 15-4	5.5		80	74.5	73.5	72	71	70	68	65	61	56	51	
RHINO 15-5	7.5		100	93	91	89	88	87	84.5	81	76	70	63	
RHINO 15-6	11		120	112	110	108	107	106	102	97	92	85	78	
RHINO 15-7	11		141	132	130	128	126	124	119	114	108	100	91	
RHINO 15-8	11		161	151	149	146	144	142	137	131	123	114	104	
RHINO 15-9	15		183	172	169	166	164	162	156	148	139	129	117	
RHINO 15-10	15		203	190	187	184	182	179	173	165	155	144	130	
RHINO 15-11	15		222	208	205	202	200	198	191	181	169	157	143	
RHINO 15-12	18.5		239	227	224	221	219	216	209	199	187	172	156	

## DIMENSION

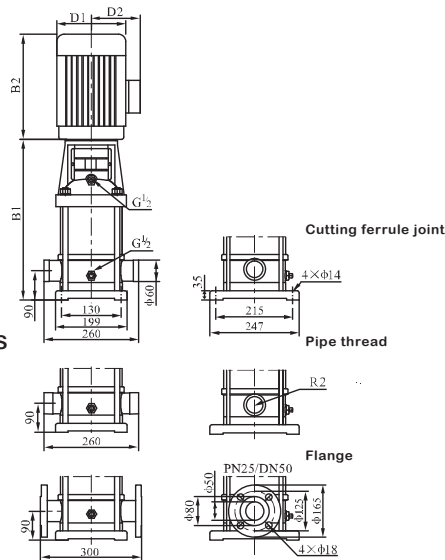

The overall dimensions of the single-phase motor and explosion-proof motor are a little different. Pls contact us for details.

## INSTALLATION

Model	Size(mm)					Weight (kg)
	B1	B2	B1+B2	D1	D2	
RHINO 15-1	400	292	692	171	119	38
RHINO 15-2	455	343	798	196	131	50
RHINO 15-3	500	348	848	215	150	59
RHINO 15-4	623	383	1006	257	167	75
RHINO 15-5	668	383	1051	257	167	81
RHINO 15-6	743	499	1242	314	258	159
RHINO 15-7	788	499	1287	314	258	161
RHINO 15-8	833	499	1332	314	258	163
RHINO 15-9	878	499	1377	314	258	176
RHINO 15-10	923	499	1422	314	258	178
RHINO 15-11	968	499	1467	314	258	180
RHINO 15-12	1013	543	1556	314	258	202

## PERFORMANCE CURVE

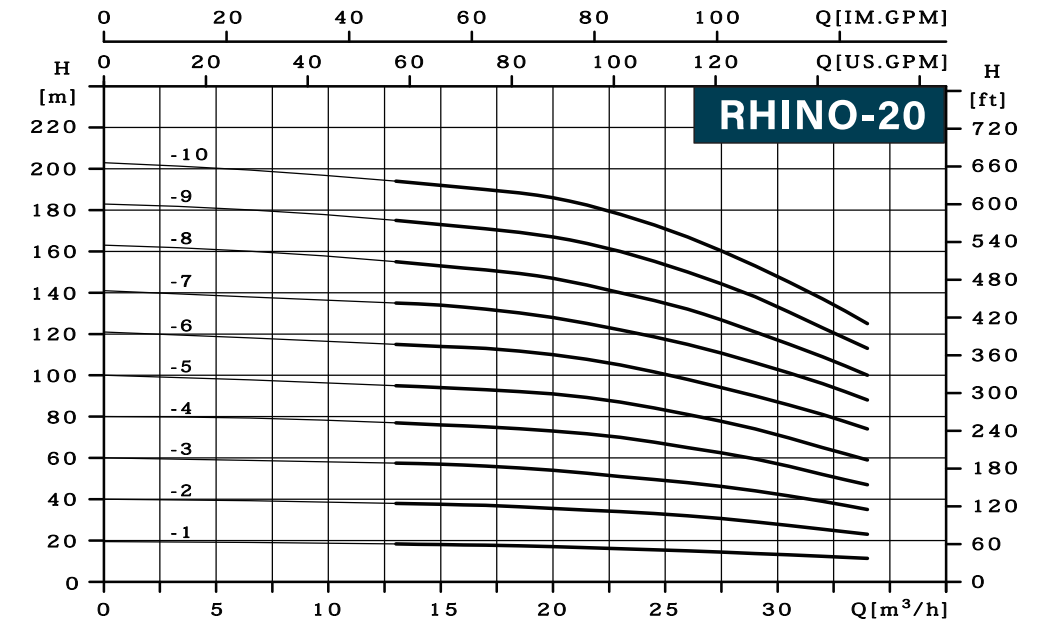

## DATA CHART

Model	Driving motor (kW)	Q (M³/H)	H (m)									
			0	13	15	17	20	23	26	29	32	34
RHINO 20-1	2.2		19.5	18.3	18	17.7	17	16	15	13.7	12.3	11.3
RHINO 20-2	4		40	38	37.5	37	35.5	34	32	29	25.5	23
RHINO 20-3	5.5		60	57.5	57	56	54	51	48	44	39	35
RHINO 20-4	7.5		80	77	76	75	73	70	65	59.5	52	47
RHINO 20-5	11		100	95	94	93	91	87	81	74	65	59
RHINO 20-6	11		121	115	114	113	110	105	98	90	81	74
RHINO 20-7	15		141	135	134	132	128	122	115	106	96	88
RHINO 20-8	15		163	155	153	151	147	140	132	121	109	100
RHINO 20-9	18.5		183	175	173	171	167	160	150	138	123	113
RHINO 20-10	18.5		203	194	192	190	186	178	167	153	137	125

## DIMENSION

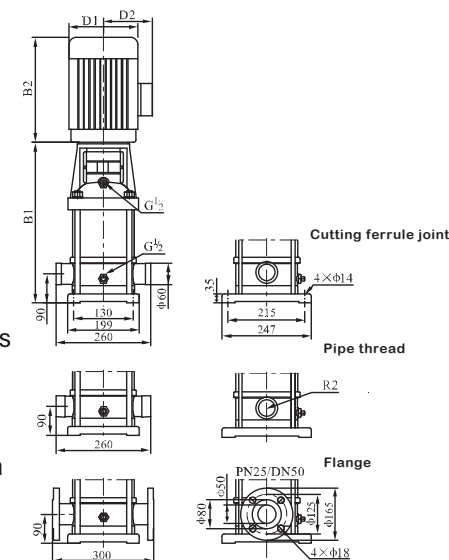

The overall dimensions of the single-phase motor and explosion-proof motor are a little different. Pls contact us for details.

## INSTALLATION

Model	Size(mm)					Weight (kg)
	B1	B2	B1+B2	D1	D2	
RHINO 20-1	400	292	692	171	119	42
RHINO 20-2	445	348	793	215	150	58
RHINO 20-3	568	383	951	257	167	73
RHINO 20-4	613	383	996	257	167	82
RHINO 20-5	688	499	1187	314	258	153
RHINO 20-6	733	499	1232	314	258	154
RHINO 20-7	778	499	1277	314	258	168
RHINO 20-8	823	499	1322	314	258	169
RHINO 20-9	868	543	1411	314	258	192
RHINO 20-10	913	543	1456	314	258	194



# PERFORMANCE CURVE

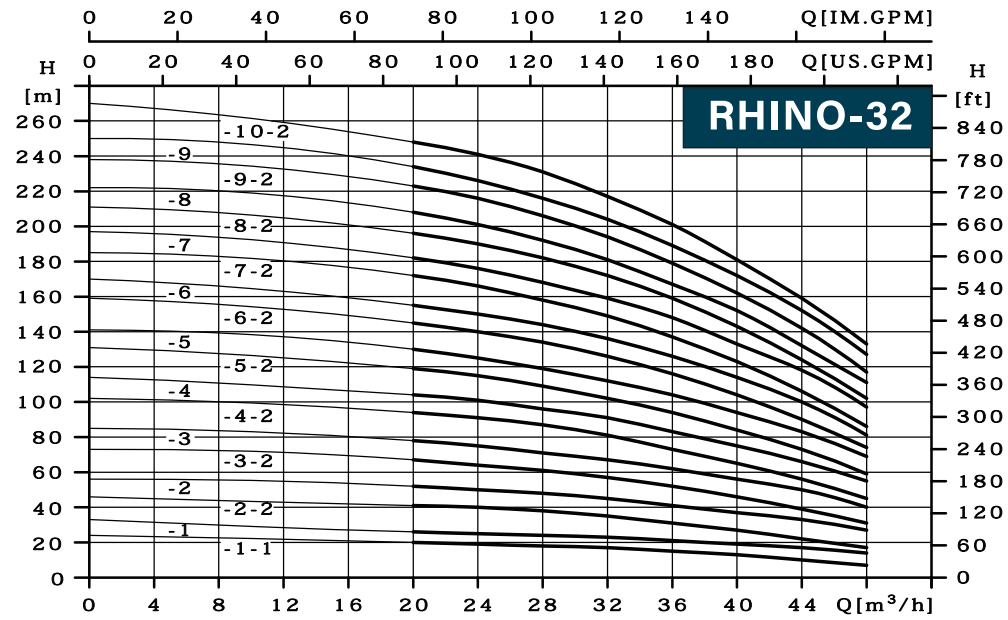

# DATA CHART

Model	Driving motor (kW)	Q (M³/H)	H (m)								
			0	20	24	28	32	36	40	44	48
RHINO 32-1-1	3		24	20	19	18	17	15	13	10	7
RHINO 32-1	4		33	26	25	24	23	21	19	17	14
RHINO 32-2-2	5.5		46	41	40	38	35	31	27	22	17
RHINO 32-2	7.5		56	52	50	48	45	41	37	33	27
RHINO 32-3-2	7.5		73	67	64	61	57	52	46	39	31
RHINO 32-3	11		85	78	75	71	67	62	56	50	40
RHINO 32-4-2	11		102	94	91	87	81	73	65	56	45
RHINO 32-4	15		114	104	101	96	91	83	75	66	55
RHINO 32-5-2	15		131	119	115	109	102	94	84	73	59
RHINO 32-5	18.5		141	130	125	119	112	104	94	83	69
RHINO 32-6-2	18.5		159	145	140	134	126	116	104	90	74
RHINO 32-6	18.5		170	155	150	144	136	126	114	100	81
RHINO 32-7-2	22		185	172	166	158	149	137	123	106	86
RHINO 32-7	22		197	182	176	168	159	148	133	118	97
RHINO 32-8-2	22		211	196	190	182	172	159	143	124	102
RHINO 32-8	30		222	208	201	192	181	167	152	132	111
RHINO 32-9-2	30		238	223	216	206	194	179	162	142	117
RHINO 32-9	30		250	234	226	216	204	189	172	152	127
RHINO 32-10-2	30		270	248	241	231	217	201	181	159	133

# DIMENSION

The overall dimensions of the single-phase motor and explosion-proof motor are a little different. Pls contact us for details.

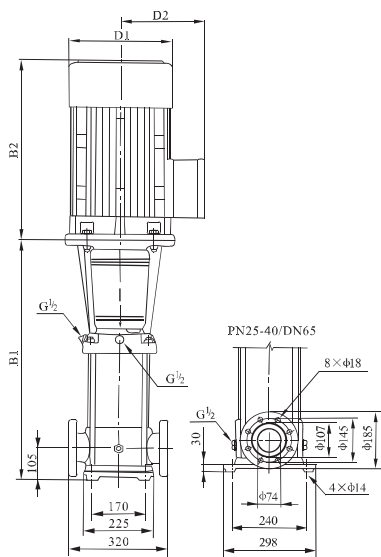

# INSTALLATION

Model	Size(mm)					Weight (kg)
	B1	B2	B1+B2	D1	D2	
RHINO 32-1-1	427	343	770	196	131	70
RHINO 32-1	427	348	775	215	150	78
RHINO 32-2-2	588	383	971	257	167	93
RHINO 32-2	588	383	971	257	167	96
RHINO 32-3-2	658	383	1041	257	167	101
RHINO 32-3	688	499	1187	314	258	175
RHINO 32-4-2	758	499	1257	314	258	180
RHINO 32-4	758	499	1257	314	258	187
RHINO 32-5-2	828	499	1327	314	258	202
RHINO 32-5	828	543	1371	314	258	215
RHINO 32-6-2	898	543	1441	314	258	220
RHINO 32-6	898	543	1441	314	258	220
RHINO 32-7-2	968	569	1537	355	274	266
RHINO 32-7	968	569	1537	355	274	266
RHINO 32-8-2	1038	569	1607	355	274	271
RHINO 32-8	1038	667	1705	397	307	326
RHINO 32-9-2	1108	667	1775	397	307	331
RHINO 32-9	1108	667	1775	397	307	331
RHINO 32-10-2	1178	667	1845	397	307	336

# PERFORMANCE CURVE

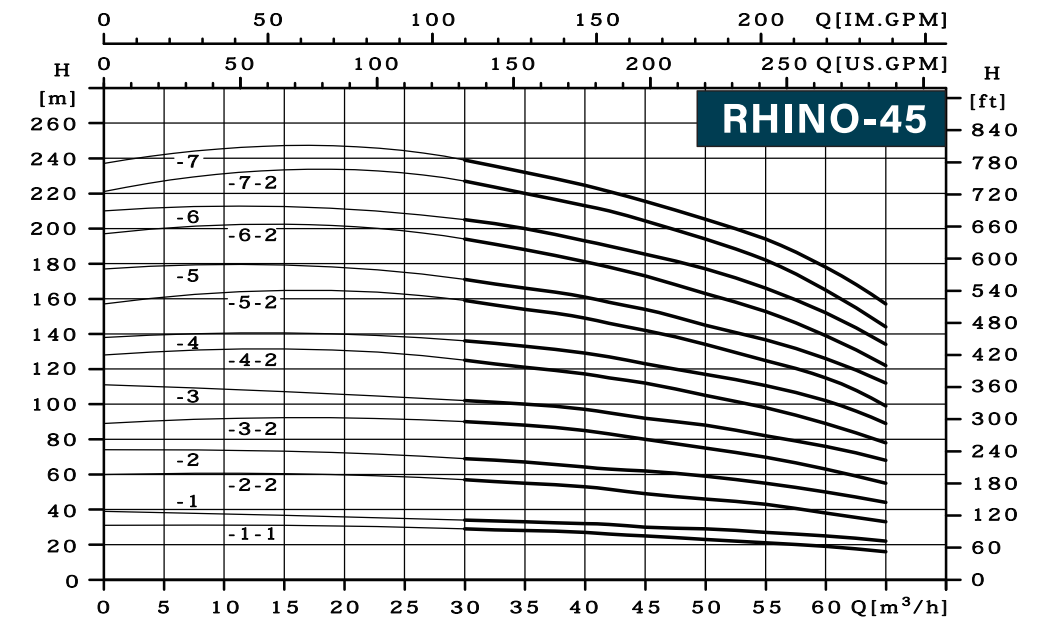

# DATA CHART

Model	Driving motor (kW)	Q (M³/H)	H (m)									
			0	30	32	40	42	45	50	55	60	65
RHINO 45-1-1	5.5		31	29	28	27	26	25	23	21	19	16
RHINO 45-1	7.5		39	34	33	32	31.5	30	29	27	25	22
RHINO 45-2-2	11		60	57	55	53	52	49	46	43	38	33
RHINO 45-2	15		74	69	67	65	63	61	59	55	50	44
RHINO 45-3-2	18.5		89	90	88	85	83	80	75	72	63	55
RHINO 45-3	18.5		111	102	100	97	95	92	88	82	76	68
RHINO 45-4-2	22		128	125	121	118	115	112	105	98	89	78
RHINO 45-4	30		138	136	133	129	126	123	117	112	102	89
RHINO 45-5-2	30		157	159	154	149	146	142	134	121	115	99
RHINO 45-5	30		177	171	166	161	158	154	145	138	126	112
RHINO 45-6-2	37		197	194	188	182	178	173	163	155	139	122
RHINO 45-6	37		210	205	200	193	190	186	176	166	152	134
RHINO 45-7-2	45		221	227	220	213	210	205	193	182	165	144
RHINO 45-7	45		237	239	232	226	221	216	204	194	178	157

# DIMENSION

The overall dimensions of the single-phase motor and explosion-proof motor are a little different. Pls contact us for details.

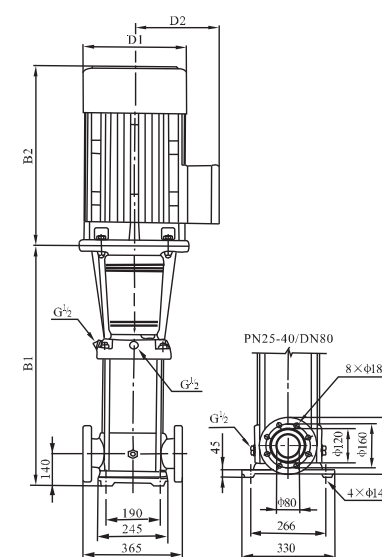

# INSTALLATION

Model	Size(mm)					Weight (kg)
	B1	B2	B1+B2	D1	D2	
RHINO 45-1-1	579	383	962	257	167	100
RHINO 45-1	579	383	962	257	167	105
RHINO 45-2-2	689	499	1188	314	258	180
RHINO 45-2	689	499	1188	315	259	191
RHINO 45-3-2	769	543	1312	314	258	201
RHINO 45-3	769	543	1312	314	258	201
RHINO 45-4-2	849	569	1418	355	274	242
RHINO 45-4	849	667	1516	397	307	296
RHINO 45-5-2	929	667	1596	397	307	301
RHINO 45-5	929	667	1596	397	307	306
RHINO 45-6-2	1009	667	1676	397	307	312
RHINO 45-6	1009	667	1676	397	307	312
RHINO 45-7-2	1089	702	1791	397	307	382
RHINO 45-7	1089	702	1791	446	330	382



# PERFORMANCE CURVE

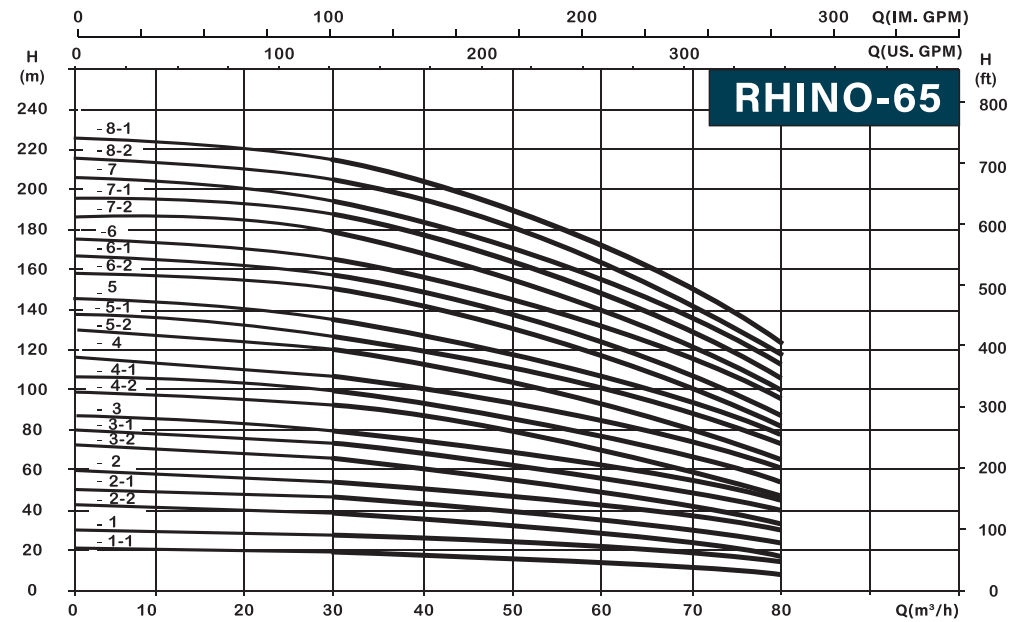

# DATA CHART

Model	Driving motor (kW)	Q (M³/H)	0	40	50	60	65	70	80	90	100
RHINO65-1-1	7.5	H (m)	30	26	25	23	22	21	18	14	10
RHINO65-1	11		43	37	35	33	32	31	28	24	21
RHINO65-2-2	15		54	53	50	47	44	42	37	31	23
RHINO65-2	22		82	74	72	67	64	62	57	51	52
RHINO65-3-2	22		97	93	88	80	76	72	65	56	54
RHINO65-3	30		122	112	108	100	96	93	86	77	65
RHINO65-4-2	37		137	130	124	115	110	103	94	83	66
RHINO65-4	45		159	152	144	135	130	123	114	102	86
RHINO65-5-2	45		171	172	162	151	144	137	126	112	91

# PERFORMANCE CURVE

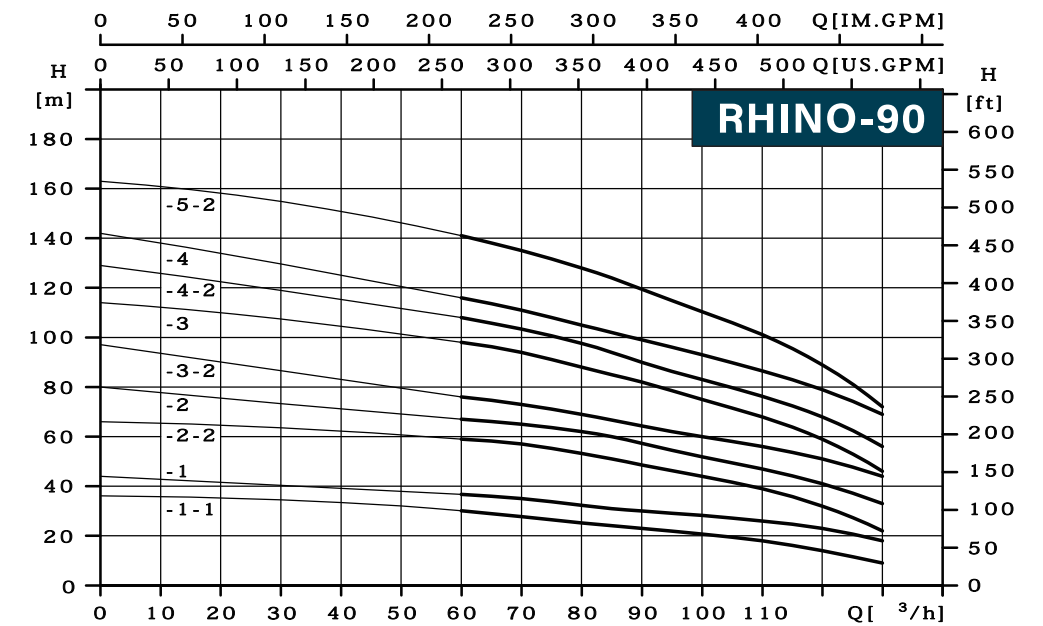

# DATA CHART

Model	Driving motor (kW)	Q (M³/H)	0	60	70	80	85	90	100	110	120	130
RHINO 90-1-1	11	H (m)	36	31	27	25	24	23	21	18	14	9
RHINO 90-1	15		44	36	35	33	31	30	29	26	23	18
RHINO 90-2-2	18.5		66	59	57	54	51	48	44	39	32	22
RHINO 90-2-1	22		80	67	65	62	59	57	51	47	41	33
RHINO 90-2	30		99	76	73	69	66	64	60	56	52	44
RHINO 90-3-2	37		114	98	94	88	85	82	75	69	59	46
RHINO 90-3-1	37		129	108	104	98	94	90	83	78	69	56
RHINO 90-3	45		142	116	111	105	102	97	93	88	79	69
RHINO 90-4-2	45		163	141	135	128	124	118	109	102	89	72

# DIMENSION

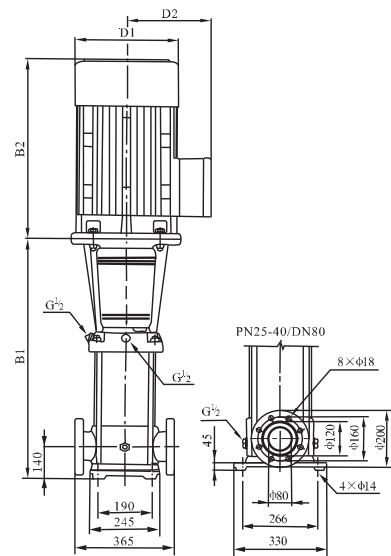

# INSTALLATION

Model	Size(mm)					Weight (kg)
	B1	B2	B1+B2	D1	D2	
RHINO65-1-1	581	383	964	257	167	98
RHINO65-1	611	499	1110	314	258	168
RHINO65-2-2	694	499	1193	314	258	178
RHINO65-2	694	569	1263	355	274	233
RHINO65-3-2	777	569	1346	355	274	238
RHINO65-3	777	667	1444	397	307	295
RHINO65-4-2	860	667	1527	397	307	325
RHINO65-4	860	702	1562	446	330	392
RHINO65-5-2	943	702	1645	446	330	397

# DIMENSION

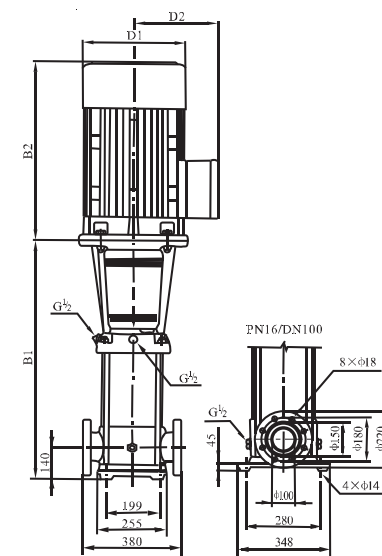

# INSTALLATION

Model	Size(mm)					Weight (kg)
	B1	B2	B1+B2	D1	D2	
RHINO 90-1-1	621	499	1120	314	258	176
RHINO 90-1	621	499	1120	314	258	182
RHINO 90-2-2	713	543	1256	314	258	205
RHINO 90-2-1	713	569	1282	355	274	248
RHINO 90-2	713	667	1380	397	307	301
RHINO 90-3-2	805	667	1472	397	307	325
RHINO 90-3-1	805	667	1472	397	307	325
RHINO 90-3	805	702	1507	446	330	394
RHINO 90-4-2	897	702	1599	446	330	400



