

STAINLESS STEEL
SUBMERSIBLE DRAINAGE PUMP

NEEMO

SERIES 50HZ



Features

- Exhaust Valve to Prevent Air Lock
- Double mechanical seal for Higher Reliability and Longevity
- Ergonomically Designed Handle
- Fully made in stainless steel AISI 304
- Free passage to 10mm in diameter
- Practical and easy to use

Applications

- Drainage of cellars, basements, garages
- Emptying of tanks and reservoirs - irrigation of lawn and garden
- Pumping of domestic grey water, washing machines, showers
- Light waste water discharge.

Specifications

	Liquid Temperature	0~40°C (32~104°F)
	Submersible depth	5M
Motor Part	Frequency	50Hz
	Pole	2 Pole
	Type	Dry Type
	Insulation	Class F
	Protection	IP 68
Pump Part	Protector	Auto-Cut
	Bearing	Ball Type
	Mechanical seal	Double Mechanical Seal
	Impeller	Semi-Open Impeller

Data Chart

Type	Output		Discharge	F.L.A.	Rated		Maximum		Free Passage	Weight(W/O Cable)	
	HP	KW			Head M	Cap. LPM	Head M	Cap. LPM		1ø-kg	3ø-kg
NEEMO-5.03	0.33	0.25	1-1/4"	2.1A	5.5	105	8.7	175	10	4.3	-

» Vertical Level Switch is optional for 0.33HP.



Float switch

Section View

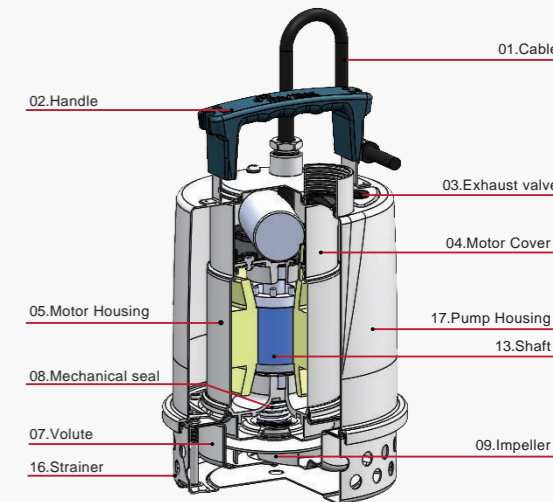

Performance Curve

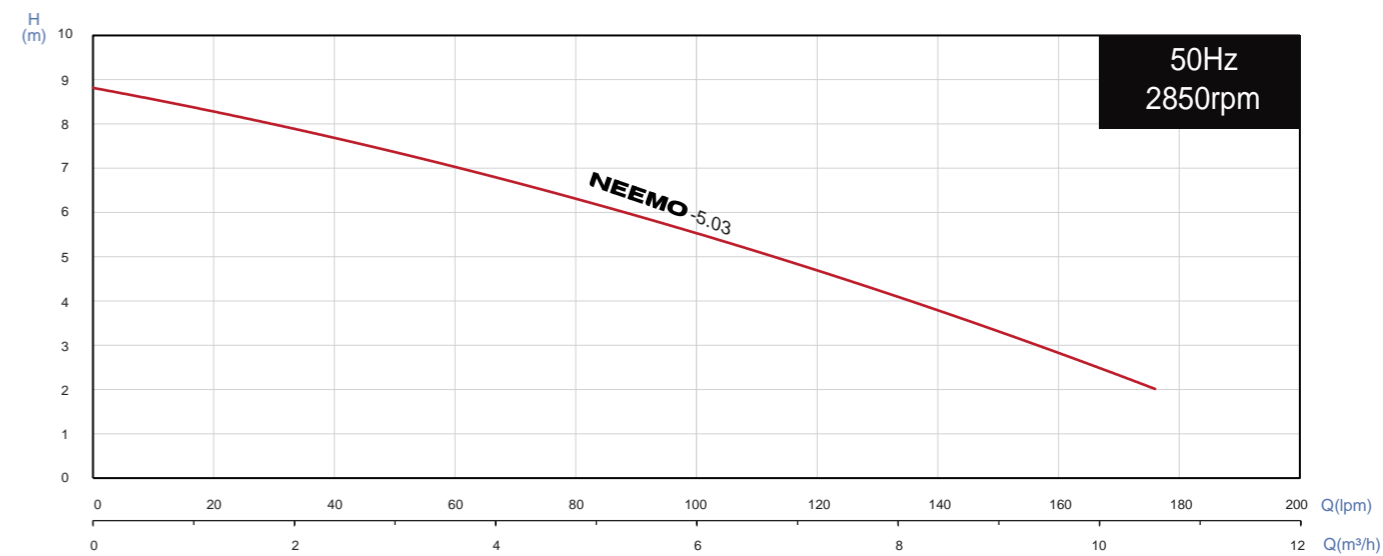

All technical information is subject to change without notice.

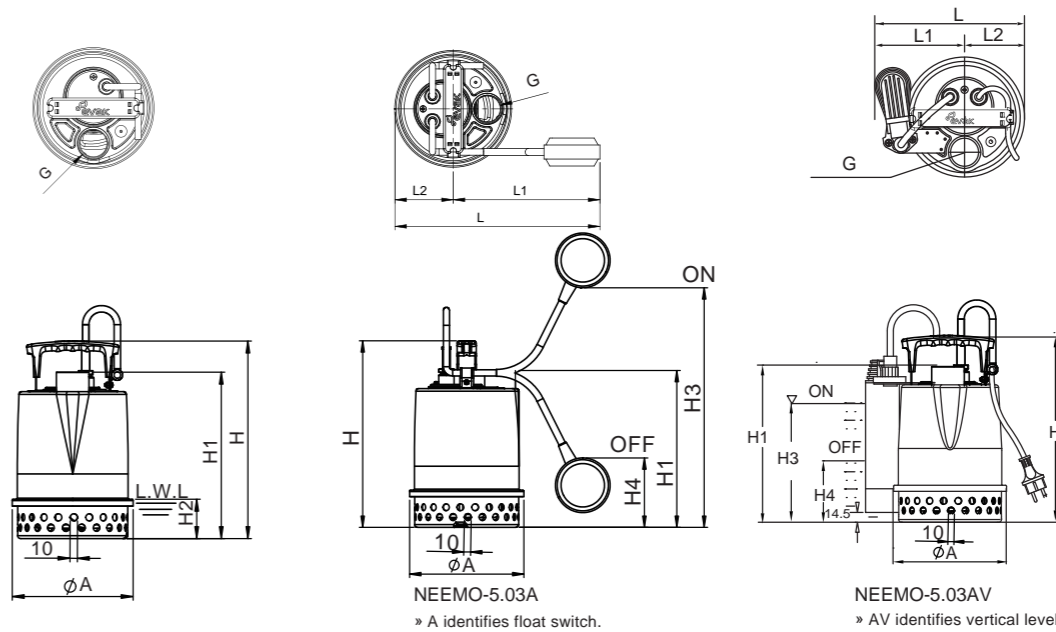

Dimensions (mm)

Type	A	L	L1	L2	G	H	H1	H2	H3	H4	WT
NEEMO-5.03	167	-	-	-	1-1/4"	272	230	54	-	-	4.3
NEEMO-5.03A	167	320.5	237	83.5	1-1/4"	272	230	-	300	150	4.5
NEEMO-5.03AV	167	208.5	125	83.5	1-1/4"	272	230	-	175	90	4.5