

2" FULL FREE PASSAGE
SUBMERSIBLE SEWAGE PUMP

HIPPO

SERIES 50HZ



HIPPO-50Q+QH coupling foot HIPPO-50Q HIPPO-Q with Elbow Kit

Features

- Vortex impeller design
- 2" discharge with PT inner thread
- 2" (50mm) solid free passage
- EKK Eagle Burgmann double mechanical seal CA/CE & SIC/SIC
- Stainless Steel motor housing

Applications

- For heavy-duty applications with soiled biological wastewater, sewage, rainwater
- For both domestic and professional use

Specifications

	Liquid Temperature	0~40°C (32~104°F)
	Submersible depth	10M
Motor Part	Frequency	50Hz
	Pole	2 Pole
	Type	Dry Type
	Insulation	Class F
	Protection	IP 68
Pump Part	Protector	Auto-cut
	Bearing	Ball Type
	Mechanical seal	Double Mechanical Seal
	Impeller	Vortex Impeller

Data Chart

Type	Output		Discharge	F.L.A.		Rated		Maximum		Free Passage	Weight(W/O Cable)	
	HP	kW		1ø 230V	3ø 400V	Head M	Cap. LPM	Head M	Cap. LPM		mm	1ø-kg
HIPPO-50(Q)	0.5	0.37	2"	4.2A	1.6A	4.5	240	8	330	50	12.9 (14.3)	12.9 (14.3)
HIPPO-75(Q)	0.75	0.55	2"	5.5A	1.8A	6.4	240	10	390	50	13.9 (15.3)	13.9 (15.3)
HIPPO-100(Q)	1	0.75	2"	7.2A	2.5A	7.7	300	11.3	500	50	15.4 (16.8)	15.4 (16.8)
HIPPO-150(Q)	1.5	1.1	2"	9A	2.8A	8	390	12.5	580	50	24.2 (26.2)	24.2 (26.2)
HIPPO-200(Q)	2	1.5	2"	12A	3.9A	10	420	15.5	660	50	25.2 (27.2)	25.2 (27.2)
HIPPO-300Q(H)	3	2.2	2"	-	3.7A (4.6A)	12	400 (480)	18.4 (20.2)	620 (690)	50	-	32.1
HIPPO-400Q(H)	4	3	2"	-	6.2A (6.7A)	16	460 (500)	21.3 (23.7)	780 (780)	47.5(50)	-	38.3
HIPPO-550Q(H)	5.5	4.1	2"	-	7.7A (8.5A)	17	630 (700)	25 (27)	880 (940)	50	-	40.3

» HIPPO series standard version features a vertical, threaded outlet pump body.
 » (Q) in the name-coding identifies the pump with horizontal flanged outlet.
 » Elbow Kit is optional for HIPPO-Q horizontal flanged outlet pump.

» QH coupling foot is suitable for HIPPO Q type models.
 » All single-phase pumps can be equipped with float switch upon request.

Section View



EB50H Elbow Kit (Optional)

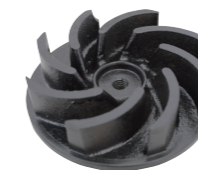

Vortex Impeller

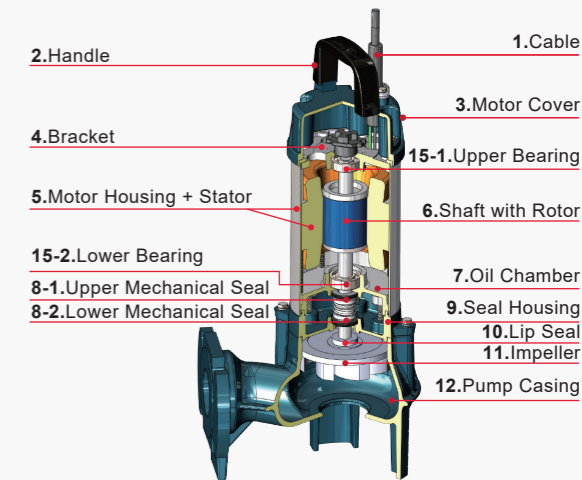

- 1.Cable
- 2.Handle
- 3.Motor Cover
- 4.Bracket
- 5.Motor Housing + Stator
- 6.Shaft with Rotor
- 7.Oil Chamber
- 8-1.Upper Mechanical Seal
- 8-2.Lower Mechanical Seal
- 9.Seal Housing
- 10.Lip Seal
- 11.Impeller
- 12.Pump Casing
- 15-1.Upper Bearing
- 15-2.Lower Bearing

Performance Curve

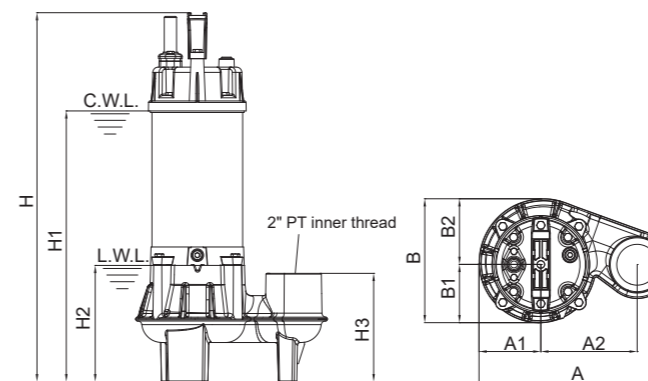
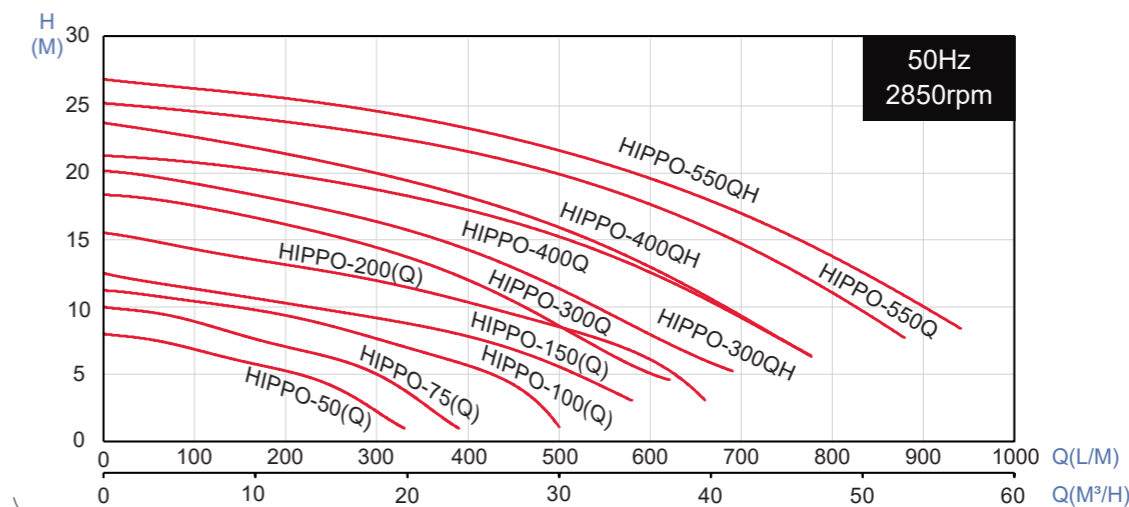

HIPPO-50-200

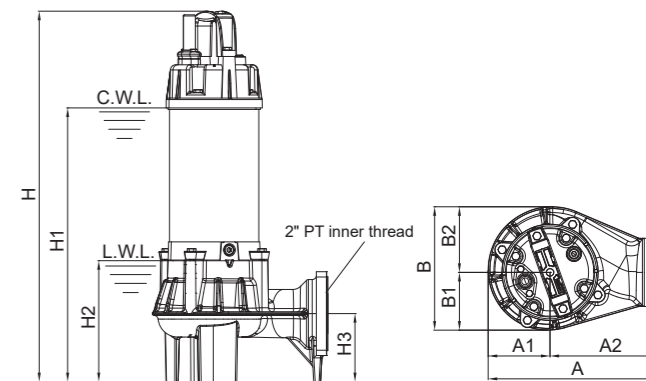

HIPPO-50Q-550Q / HIPPO-300QH-550QH

Dimensions (mm)

Type	A	A1	A2	B	B1	B2	H	H1	H2	H3
HIPPO-50	260	89	125	170	90	80	466	336	151	141
HIPPO-50Q	235	85	150	170	85	85	470	342	161	90
HIPPO-75	260	89	125	170	90	80	482	352	151	141
HIPPO-75Q	235	85	150	170	85	85	486	358	161	90
HIPPO-100	260	89	125	170	90	80	496	366	151	141
HIPPO-100Q	235	85	150	170	85	85	500	372	161	90
HIPPO-150	272	93	130	187	87	100	506	376	151	143
HIPPO-150Q	248	93	155	190	95	95	510	373	158	90
HIPPO-200	272	93	130	187	87	100	520	396	151	143
HIPPO-200Q	248	93	155	190	95	95	530	393	158	90
HIPPO-300Q(H)	275	105	170	200	100	100	625	455	158	90
HIPPO-400Q(H)	275	105	170	200	100	100	648	478	158	90
HIPPO-550Q(H)	275	105	170	200	100	100	678	508	158	90