

2.5" & 3" FULL FREE PASSAGE
SUBMERSIBLE SEWAGE PUMP

HIPPO DN

SERIES 60HZ



Vortex Impeller



HIPPO-150 DN80 with QD-80



HIPPO-200 DN65

Features

- Vortex impeller design
- 2.5" & 3" (65mm & 76mm) solid free passage
- EKK Eagle Burgmann double mechanical seal CA/CE & SIC/SIC
- Stainless Steel motor housing
- Volute connection available in DIN PN10/16

Applications

- For heavy-duty applications with soiled biological wastewater, sewage, rainwater
- For both domestic and professional use

Specifications

Liquid Temperature	0~40°C (32~104°F)	
Submersible depth	10M	
Motor Part	Frequency	60Hz
	Pole	2 Pole
	Type	Dry Type
	Insulation	Class B
	Protection	IP 68
Pump Part	Protector	Auto-cut
	Bearing	Ball Type
	Mechanical seal	Double Mechanical Seal
	Impeller	Vortex Impeller

Data Chart

Type	Output		Discharge	F.L.A.			Rated		Maximum		Free Passage	Weight(W/O Cable)		Q.D.C.
	HP	kW		1ø 230V	3ø 230V	3ø 460V	Head FT	Cap. GPM	Head FT	Cap. GPM		mm	1ø-kg	
HIPPO-150 DN65	1.5	1.1	2.5"	8A	4.6A	2.3A	11.5	130	31.3	160	65	26.3	26.3	QM-65
HIPPO-200 DN65	2	1.5	2.5"	9.9A	7.2A	3.6A	24.6	105	45	193	65	28.5	28.5	QM-65
HIPPO-300 DN65	3	2.2	2.5"	-	10A	5A	33	120	57	248	65	-	29.6	QM-65
HIPPO-150 DN80	1.5	1.1	3"	10.1A	6A	3A	11.5	130	22	185.5	76	29.6	29.6	QD-80
HIPPO-200 DN80	2	1.5	3"	11A	7.8A	3.9A	14	125	28	194.5	76	31.8	31.8	QD-80
HIPPO-300 DN80	3	2.2	3"	-	10.4A	5.2A	18	185	39.5	275	76	-	32.9	QD-80

» All single-phase pumps can be equipped with float switch upon request.

Performance Curve

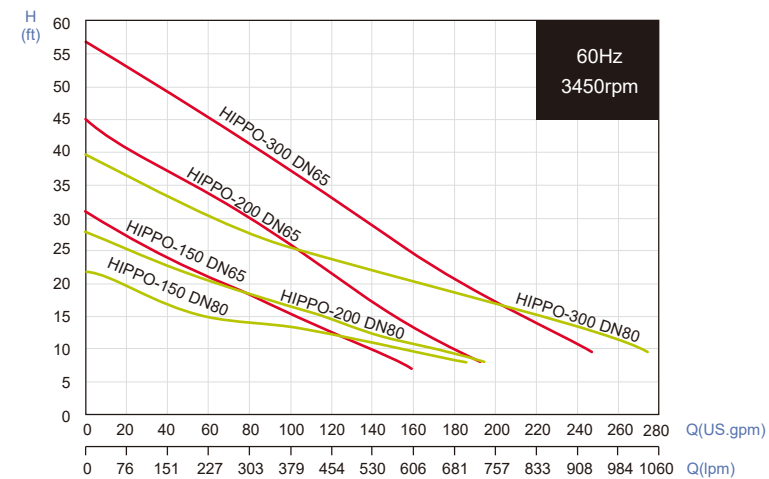

All technical information is subject to change without notice.

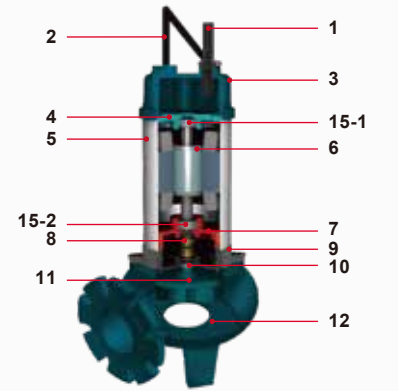

Parts and Material List

No.	Part	Material
1	Cable	H07RN-F/SJTOW/STOW
2	Handle	ASTM A36
3	Motor Cover	ASTM A48 Class 30
4	Bracket	ASTM A48 Class 30
5	Motor Housing + Stator	AISI 304
6	Shaft with Rotor	AISI 410
7	Oil Chamber	ASTM A48 Class 30
8	Mechanical Seal	Upper : CA / CE Lower : SIC / SIC
9	Seal Housing	ASTM A48 Class 30
10	Lip Seal	BUNA N
11	Impeller	ASTM A48 Class 30
12	Pump Casing	ASTM A48 Class 30
15-1	Upper Bearing	NTN/TPI
15-2	Lower Bearing	NTN/TPI

Note: Single lower bearing for 1.5HP/2HP;
Double lower bearings for 3HP
TPI is a family brand of NTN group.

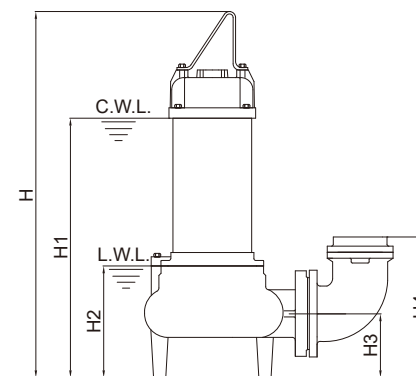
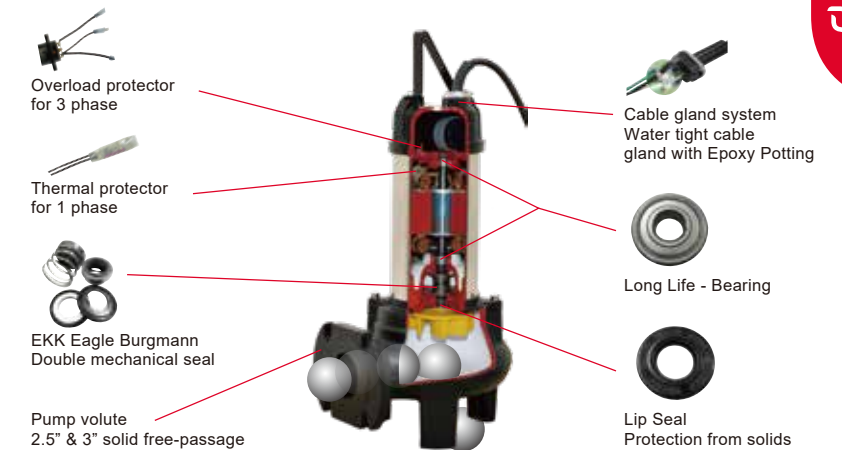
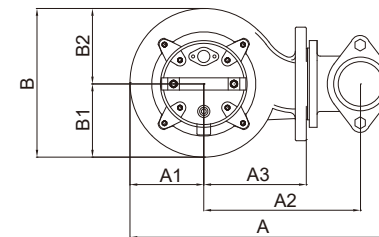

HIPPO-150~300 DN65

Dimensions (mm)

Type	A	A1	A2	A3	B	B1	B2	H	H1	H2	H3	H4
HIPPO-150 DN65	410	145	240	180	235	120	115	580	405	185	105	215
HIPPO-200 DN65	410	145	240	180	235	120	115	600	425	185	105	215
HIPPO-300 DN65	410	145	240	180	235	120	115	630	455	185	105	215
HIPPO-150 DN80	550	122	320	180	257	127	130	615	440	220	130	270
HIPPO-200 DN80	550	122	320	180	257	127	130	635	460	220	130	270
HIPPO-300 DN80	550	122	320	180	257	127	130	665	490	220	130	270