

**LIGHTWEIGHT SUBMERSIBLE RESIDUE DEWATERING PUMP**

**EUSR**  
SERIES 50HZ



**Features**

- Submersible single-phase portable residue dewatering pump
- Rubber lined base plate protects the floor surface from scratching
- The wear parts are made of abrasion-resistant materials
- Discharge direction is selectable between vertical and horizontal
- Removal of residual water down to 3mm

**Applications**

- Residential, commercial, industrial dewatering and site drainage
- Construction sites and civil engineering projects
- Basement, parking lots, removing residue water

**Data Chart**

Type	Output		Discharge	F.L.A.		Rated		Maximum		Weight(W/O Cable)	
	HP	kW		1ø 230V	3ø 400V	Head M	Cap. LPM	Head M	Cap. LPM	1ø-kg	3ø-kg
50EUSR-5.05	0.5	0.37	2"	3A	0.9A	10	75	14	140	11.3	11.3

**Specifications**

	Liquid Temperature	0~40°C (32~104°F)
	Submersible depth	10M
<b>Motor Part</b>	Frequency	50Hz
	Pole	2 Pole
	Type	Dry Type
	Insulation	Class B
	Protection	IP 68
<b>Pump Part</b>	Protector	Auto-cut
	Bearing	Ball Type
	Mechanical seal	Double Mechanical Seal
	Impeller	Semi-open Impeller



**KLIXON**  
1PH Protector  
(Thermal)



**KLIXON**  
1PH Protector  
(optional)  
(overheat & overload)



**KLIXON**  
3PH Protector  
(overheat, overload,  
phase failure)



**DU PONT Hytrel®**  
Steel coated with  
thermoplastic  
polyester elastomer

**KLIXON**

KLIXON protector provides protection against overheating and stalled rotor conditions including:

- Plugging duty
- Stalling or failure to start
- Heavy overloads
- High ambient
- Ventilation failures

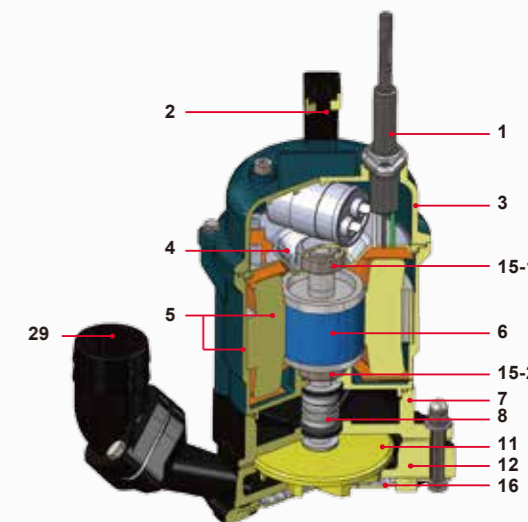

**Parts and Material List**

No.	Part	Material
1	Cable	H07RN-F
2	Handle	Nylon 6
3	Motor Cover	ADC 12
4	Bracket	Steel
5	Motor Housing + Stator	ADC12+Steel
6	Shaft with Rotor	AISI 410
7	Oil Chamber	Cast Iron
8	Mechanical Seal	Upper : CA/CE Lower : SIC/SIC
11	Impeller	Hytrel
12	Pump Casing	EN-GJL-200
15-1	Upper Bearing	NTN/TPI
15-2	Lower Bearing	NTN/TPI
16	Strainer	Steel+Rubber
29	Plastic Hosetail	PP

TPI is a family brand of NTN group.

**Dimensions (mm)** Pumping water down to minimum level of 3mm

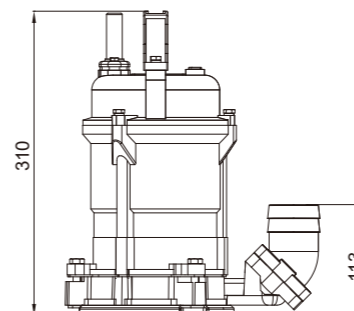
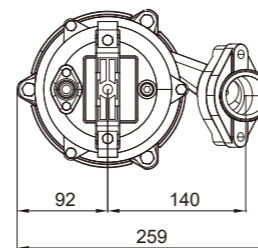

**Performance Curve**

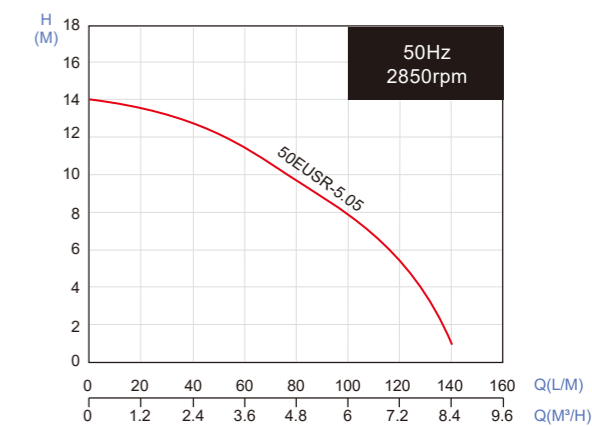

All technical information is subject to change without notice.