

LIGHTWEIGHT SUBMERSIBLE RESIDUE DEWATERING PUMP

EUBR
EUBRS AISI 304
EUBRI AISI 316
SERIES 50HZ



DU PONT Hytrel®
 Steel coated with thermoplastic polyester elastomer



Loss Wax Stainless Steel AISI 304 & 316 EUBRS(I) Impeller

Features

- High resistance to abrasive liquids
- Loss wax casting AISI 304 & AISI 316 for EUBRS and EUBRI
- Viton gasket, O-rings, and Lip seal for EUBRI (AISI 316)
- Compact & Lightweight design
- Puddle or residue drainage down to 3mm
- Efficient circumferential cooling for continuous duty

Applications

- Site drainage, mining, tunneling, public works, floods
- Cement industry, river intake, civil engineering projects
- Basement, parking lots, removing residue water (EUBR/EUBRS/EUBRI)
- Version "S" in AISI 304 and "I" in AISI 316 are suitable for light chemical liquids in drainage and general pumping applications

Data Chart

Type	Output		Discharge	F.L.A.		Rated		Maximum		Free Passage	Weight(W/O Cable)
	HP	kW		1ø 230V	3ø 400V	Head M	Cap. LPM	Head M	Cap. LPM		
50EUBR-5.05	0.5	0.37	2"	3A	0.9A	8	115	11	205	2	12
50EUBRS(I)-5.05	0.5	0.37	2"	3A	0.9A	8	130	11.5	230	2	14.6(13.8)
50EUBR-5.10	1	0.75	2"	6.3A	1.9A	10	225	17	320	2	14.5
50EUBRS(I)-5.10	1	0.75	2"	6A	1.9A	10	220	16	330	2	17.8(16.5)

Specifications

Liquid Temperature	0~40°C (32~104°F)	
Submersible depth	10M	
Motor Part	Frequency	50Hz
	Pole	2 Pole
	Type	Dry Type
	Insulation	Class B
	Protection	IP 68
	Pump Part	Protector
Bearing		Ball Type
Mechanical seal		Double Mechanical Seal
Impeller		Semi-open Impeller



KLIXON protector provides protection against overheating from all running and stalled rotor conditions including:

- Plugging duty
- Stalling or failure to start
- Heavy overloads
- High ambient
- Ventilation failures



1PH Protector (Thermal)

3PH Protector (overheat, overload, phase failure)

1PH Protector (optional) (overheat & overload)

Viton gasket, O-rings, and Lip seal for EUBRI (AISI 316)

Section View

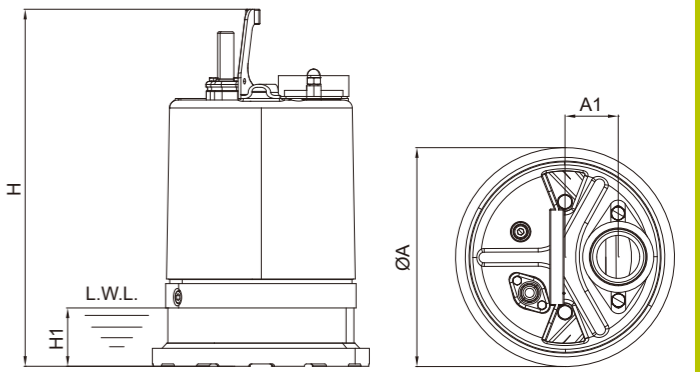
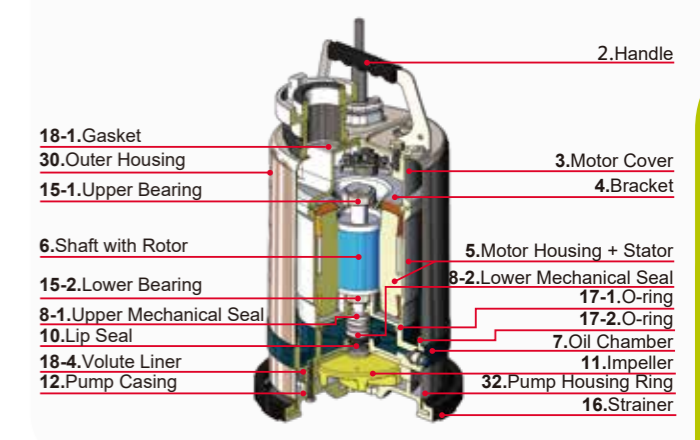

Dimensions (mm)

Type	A	A1	H	H1
50EUBR-5.05	214	52	347	52
50EUBRS(I)-5.05	184	52	345	52(50)
50EUBR-5.10	214	52	372	52
50EUBRS(I)-5.10	184	52	370	52(50)

Performance Curve

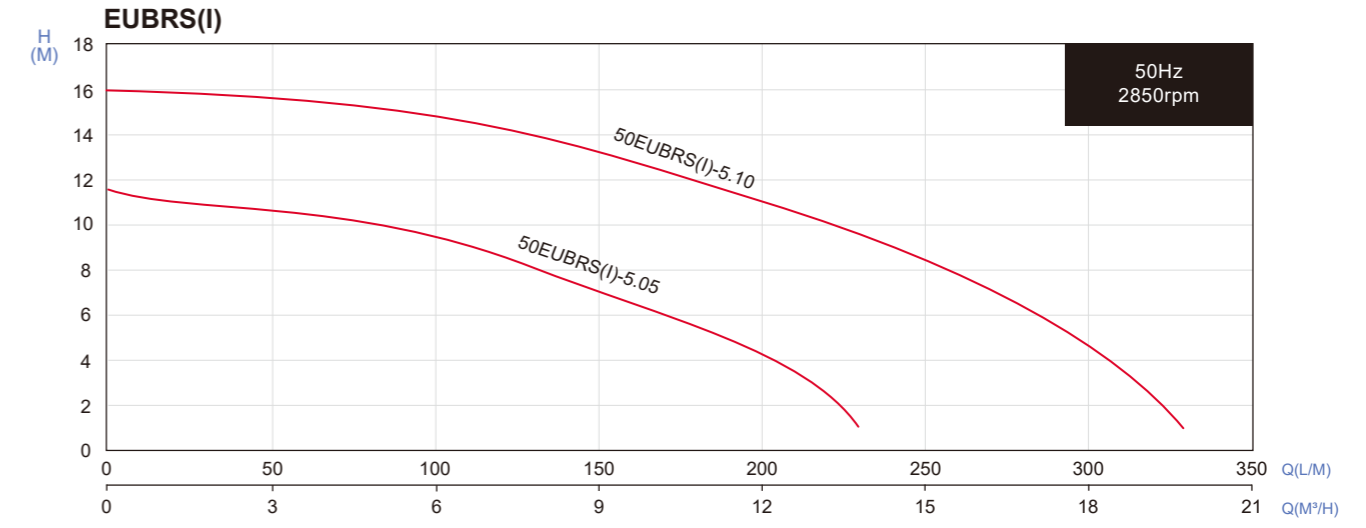
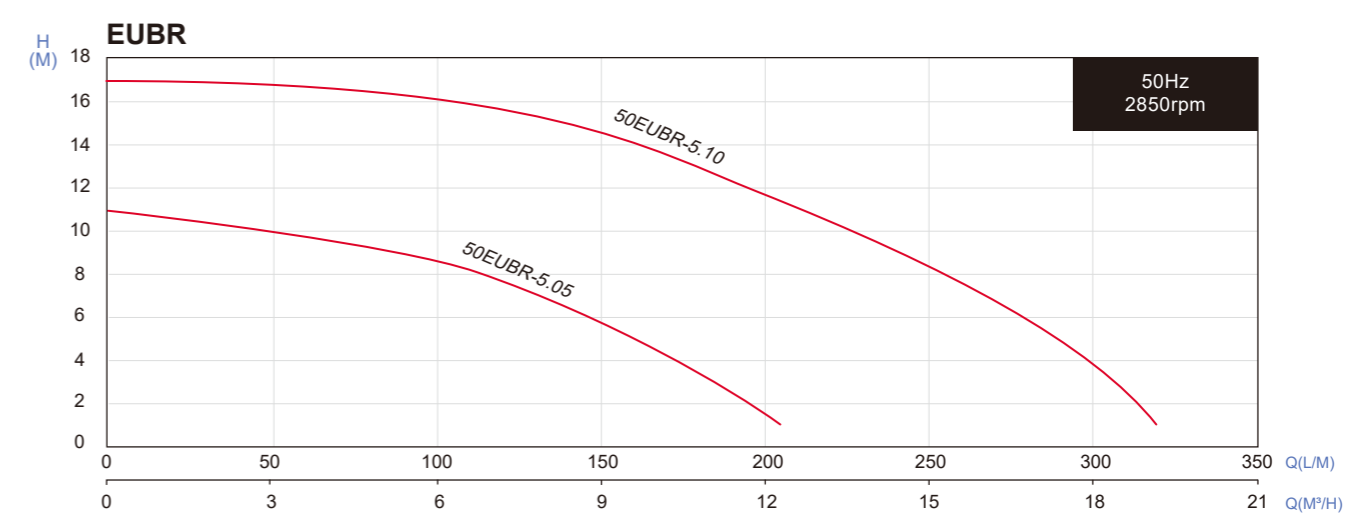

All technical information is subject to change without notice.