

LIGHTWEIGHT SUBMERSIBLE DEWATERING PUMP

EUB
EUBS AISI 304
EUBI AISI 316
SERIES 50HZ



Features

- High resistance to abrasive liquids
- Loss wax casting AISI 304 and AISI 316 for EUBS and EUBI
- Viton gasket, O-rings, and Lip seal for EUBI (AISI 316)
- Compact & Lightweight design
- Efficient circumferential cooling for continuous duty

Applications

- Site drainage, mining, tunneling, public works, floods
- Cement industry, river intake, civil engineering projects
- Version "S" in AISI 304 and "I" in AISI 316 are suitable for light chemical liquids in drainage and general pumping applications

Data Chart

Type	Output		Discharge	F.L.A.		Rated		Maximum		Free Passage	Weight(W/O Cable)	
	HP	kW		1ø 230V	3ø 400V	Head M	Cap. LPM	Head M	Cap. LPM		mm	1ø-kg
50EUB-5.05	0.5	0.37	2"	3A	0.9A	8	125	10.5	225	6	11.3	11.3
50EUBS(I)-5.05	0.5	0.37	2"	3A	0.9A	8	125	10.5	225	6	14.1(13.8)	14.1(13.8)
50EUB-5.10	1	0.75	2"	6A	1.9A	10	225	16.5	345	6	13.7	13.7
50EUBS(I)-5.10	1	0.75	2"	6A	1.9A	10	205	15.5	330	6	17.2(16.7)	17.2(16.7)
50(80)EUB-5.20	2	1.5	2"(3")	12A	3.5A	11	275	19.5	470	6	21.1	21.1
50(80)EUBS-5.20	2	1.5	2"(3")	12A	3.5A	11	215	18	470	6	25	25

» Float switch is optional for above pump in single phase.

Specifications

Liquid Temperature	0~40°C (32~104°F)	
Submersible depth	10M	
Motor Part	Frequency	50Hz
	Pole	2 Pole
	Type	Dry Type
	Insulation	0.5~1HP:Class B ; 2HP:Class F
	Protection	IP 68
Pump Part	Protector	Auto-cut
	Bearing	Ball Type
	Mechanical seal	Double Mechanical Seal
	Impeller	Semi-open Impeller

KLIXON protector provides protection against overheating from all running and stalled rotor conditions including:

- Plugging duty
- Stalling or failure to start
- Heavy overloads
- High ambient
- Ventilation failures



KLIXON
1PH Protector (Thermal)



KLIXON
1PH Protector (optional) (overheat & overload)



KLIXON
3PH Protector (overheat, overload, phase failure)



DU PONT Hytrel
Steel coated with thermoplastic polyester elastomer



Loss Wax Stainless Steel AISI 304 & 316 EUBS(I) Impeller



Viton gasket, O-rings, and Lip seal for EUBI (AISI 316)

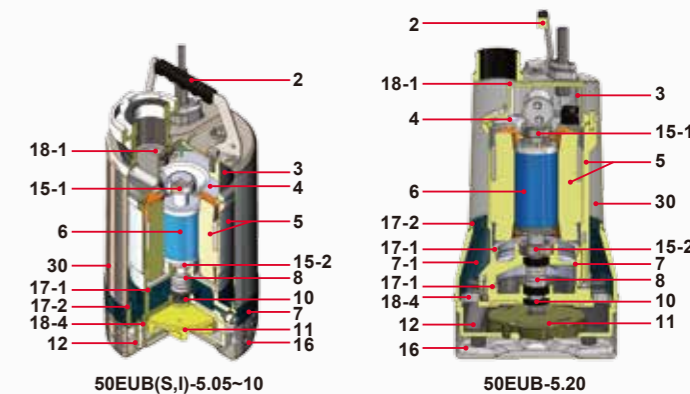

Parts and Material List

No.	Part	Material			
		EUB (0.5~1HP)	EUB (2HP)	EUBS	EUBI
2	Handle	Steel+NBR	Steel+NBR	AISI 304+NBR	AISI 304+NBR
3	Motor Cover	ADC 12	ADC 12	AISI 304	AISI 316
4	Bracket	Steel	Steel	EN-GJL-200	EN-GJL-200
5	Motor Housing + Stator	ADC12+Steel	ADC12+Steel	AISI 304	AISI 316
6	Shaft with Rotor	AISI 410	AISI 410	AISI 304	AISI 316
7	Oil Chamber	ADC 12	AISI7Mg	AISI 304	AISI 316
7-1	Oil Chamber	-	AISI7Mg	-	-
8	Mechanical Seal	CA/CE+SIC/SIC			
10	Lip Seal	NBR	NBR	NBR	VITON
11	Impeller	Hytrel	Hytrel	AISI 304	AISI 316
12	Pump Casing	EN-GJL-200	EN-GJL-200	AISI 304	AISI 316
15-1	Upper Bearing	NTN/TPI			
15-2	Lower Bearing	NTN/TPI			
16	Strainer	AISI 304	AISI 304	AISI 304	AISI 316
17-1	O-ring	NBR	NBR	NBR	VITON
17-2	O-ring	NBR	NBR	NBR	VITON
18-1	Gasket	NBR	NBR	EPDM	VITON
18-4	Volute Liner	NBR	NBR	EPDM	EPDM
30	Outer Housing	AISI 304	AISI 304	AISI 304	AISI 316

TPI is a family brand of NTN group.

Performance Curve

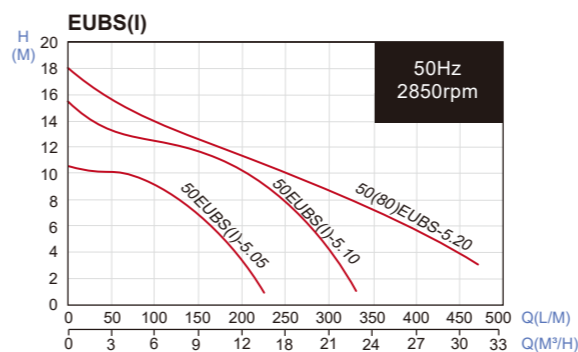
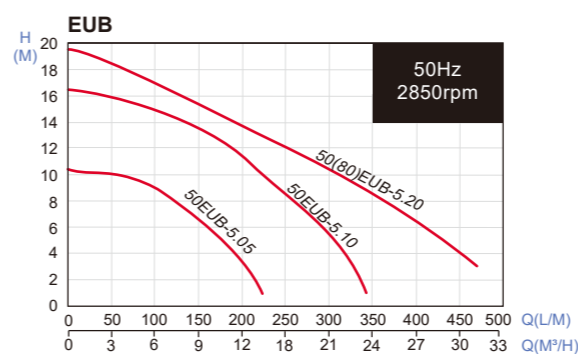

All technical information is subject to change without notice.

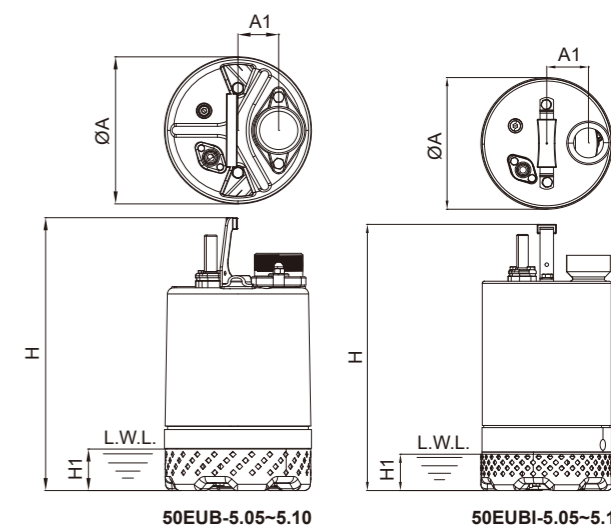

Dimensions (mm)

Type	A	A1	H	H1
50EUB-5.05	188	52	345	53
50EUBS(I)-5.05	188(184)	52	345	52
50EUB-5.10	188	52	370	53
50EUBS(I)-5.10	188(184)	52	370	52
50(80)EUB-5.20	225	52	474	81
50(80)EUBS-5.20	225	52	455	81