

## SUBMERSIBLE DEWATERING PUMP

# EDW

## SERIES 60HZ



High Efficiency Closed Impeller



Chromium nickel material  
Excellent against corrosion  
Expelling solid design  
on the back of the impeller

### Features

- Efficient circumferential cooling for continuous duty
- Dry motor design with thermal auto-cut protector, protects motor from overheating
- Robust cable entry with epoxy potted sealing and strain-relief removes the risk of leakage into motor
- Ni Chrome Steel impeller for abrasive liquids
- In-line installation applicable by replacing strainer with a check valve or adapter flange
- Double mechanical seal and lip seal to ensure long life operation

### Applications

- Agriculture industry: irrigation and underground water
- Aquaculture industry: drainage and water supply of fresh water
- Extraction of water from rivers, lakes and reservoirs
- Landscape use and horticulture irrigation related operation

### Data Chart

Type	Output		Discharge Inch	F.L.A.			Rated		Maximum		Free Passage mm	Weight(W/O Cable)	
	HP	kW		1ø 230V	3ø 230V	3ø 460V	Head FT	Cap. GPM	Head FT	Cap. GPM		1ø-kg	3ø-kg
80EDW-6.20(CH)	2	1.5	3"	11A	6.6A	3.8A	31	132	53	227	10	47	46
80EDW-6.30(CH)	3	2.2	3"	15A	9.5A	5.2A	46	132	72	259	10	46	45
100EDW-6.30(CH)	3	2.2	4"	15A	9.5A	5.2A	31	211	56	317	10	47	46
80EDW-6.50(CH)	5	3.7	3"	-	15A	8.2A	70.5	132	105	259	10	-	49.5
100EDW-6.50(CH)	5	3.7	4"	-	15A	8.2A	41	265	72	444	10	-	50.5

» (CH) is optional for customized request model with high chrome enclosed impeller, heat treated ductile-iron suction plate and AISI 410 heat treated shaft

### Performance Curve

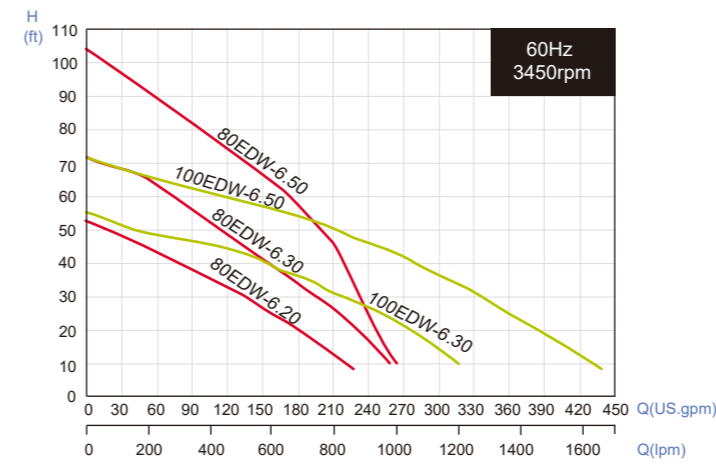

All technical information is subject to change without notice.

### Optional Accessories



Sacrificial anode  
PEDW-SA-M10



Flange kits  
3", 4" PEDW-FLK



Flange  
3", 4" PEDW-FL



Adapter flange  
3", 4" PEDW-ADF



Check valve  
3", 4" PEDW-CKV



High chrome enclosed impeller  
Heat treated ductile-iron suction plate  
AISI 410 Heat treated shaft  
(Optional for customized request)

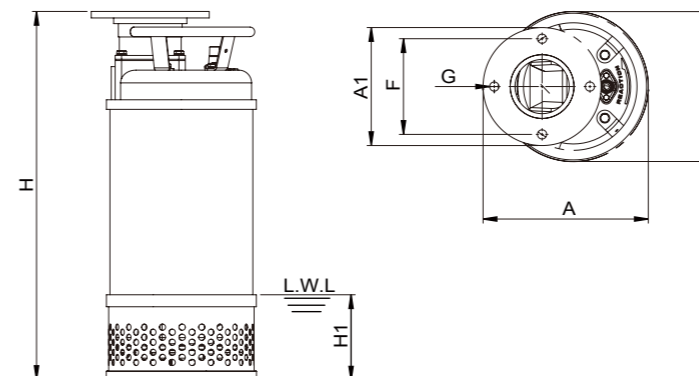

### Dimensions (mm)

Type	A	A1	A2	H	H1	F	G
80EDW-6.20S	247	160	235	568	209	125	14.5
80EDW-6.20T	247	160	235	523	187	125	14.5
80EDW-6.30S	260	185	235	568	209	150	14.5
80EDW-6.30T	260	185	235	523	187	150	14.5
100EDW-6.30S	260	185	235	568	209	150	14.5
100EDW-6.30T	260	185	235	523	187	150	14.5
80EDW-6.50T	260	185	235	548	187	150	14.5
100EDW-6.50T	260	185	235	548	187	150	14.5

» S : Single Phase ; T : Three Phase

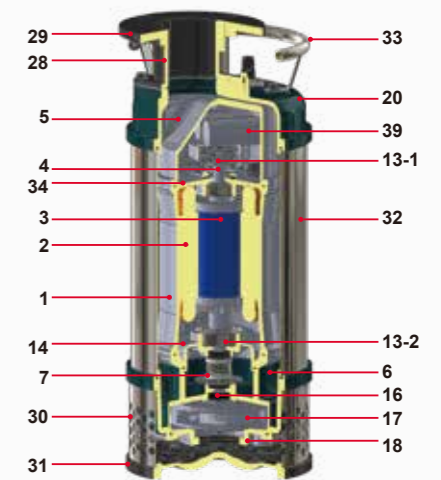

### Parts and Material List

No.	Part	Material
1	Motor Frame	ASTM A48 Class 30
2	Stator	
3&4	Shaft with Rotor	AISI 304
5	Motor Cover	ASTM A48 Class 30
6	Pump Casing	ASTM A48 Class 30
7	Mechanical Seal	Upper: CA/CE Lower: SIC/SIC
13-1	Upper Bearing	NTN/TPI
13-2	Lower Bearing	NTN/TPI
14	Lower Bearing Bracket	ASTM A48 Class 30
16	Shaft Sleeve	AISI 304
17	Impeller	Ni Chrome Steel
18	Suction Plate	ASTM A48 Class 30
20	Upper Cover	ASTM A48 Class 30
28	Discharge	ASTM A48 Class 30
29	Flange	ASTM A48 Class 30
30	Strainer	AISI 304
31	Base Plate	ASTM A48 Class 30
32	Outer Case	AISI 304
33	Handle	AISI 304
34	Upper Bearing Bracket (1PH)	ASTM A48 Class 30
39	Start&Run Capacitor	-

TPI is a family brand of NTN group.