

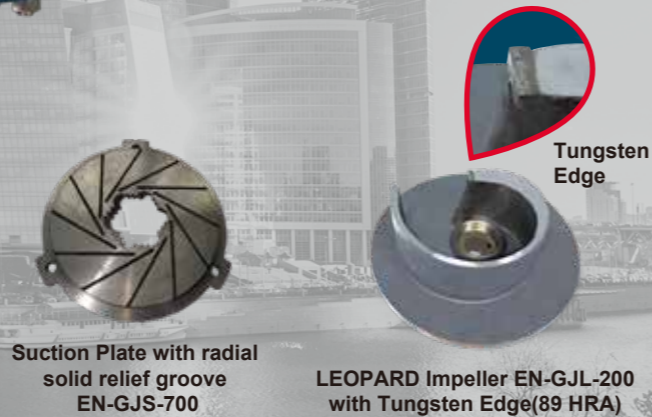

SUBMERSIBLE CUTTER PUMP

LEOPARD

SERIES 50HZ



Features

- Non clog operation with cutting action
- Robust construction
- EKK Eagle Burgmann double mechanical seal CA/CE & SIC/SIC
- Built-in motor protection
- Tungsten Edge hardness is 89HRA
- Volute 4 inch connection available in JIS 10K, ANSI 125/150 and DIN PN10/16
- 3HP volute connection available for 3 inch in DIN PN10/16
- Adjustable clearance construction to maintain performance

Applications

- Sewage
- Storm water drainage
- Wastewater
- Commercial building

Specifications

Liquid Temperature		0~40°C (32~104°F)
Submersible depth		10M
Motor Part	Frequency	50Hz
	Pole	4 Pole
	Type	Dry Type
	Insulation	Class F
Pump Part	Protection	IP 68
	Protector	Auto-cut
	Bearing	Ball Type
	Mechanical seal	Double Mechanical Seal
Impeller		Semi-open Channel Impeller

Data Chart

Type	Output		Discharge	F.L.A.		Rated		Maximum		Free Passage	Weight(W/O Cable)		Q.D.C.
	HP	kW		1ø 230V	3ø 400V	Head M	Cap. LPM	Head M	Cap. LPM		mm	1ø-kg	
80(100)LEOPARD-5.30	3	2.2	3"(4")	-	5A	8	700	14	1400	56	-	75	QL-100
100LEOPARD-5.50	5	3.7	4"	-	8.2A	11	800	16	1900	80	-	90	QL-100
100LEOPARD-5.75	7.5	5.5	4"	-	12.1A	13	800	18	2300	68	-	140	QL-100
100LEOPARD-5.100	10	7.5	4"	-	15.9A	16	850	23	2500	68	-	166	QL-100

Section View



100LEOPARD-5.30~100 with QL-100 Q.D.C.

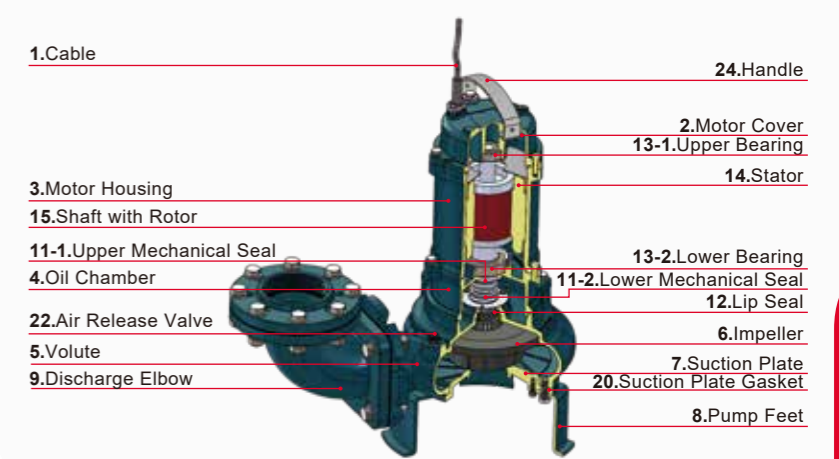

Performance Curve

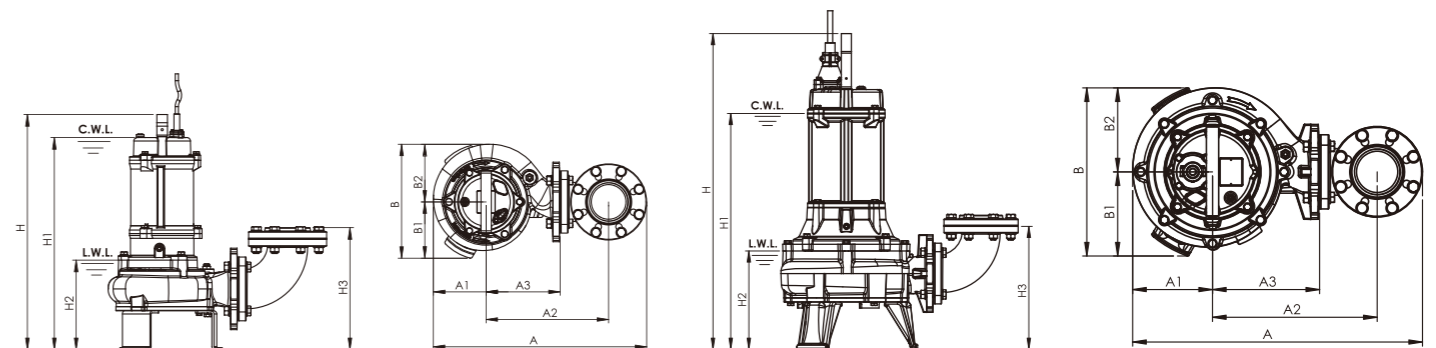
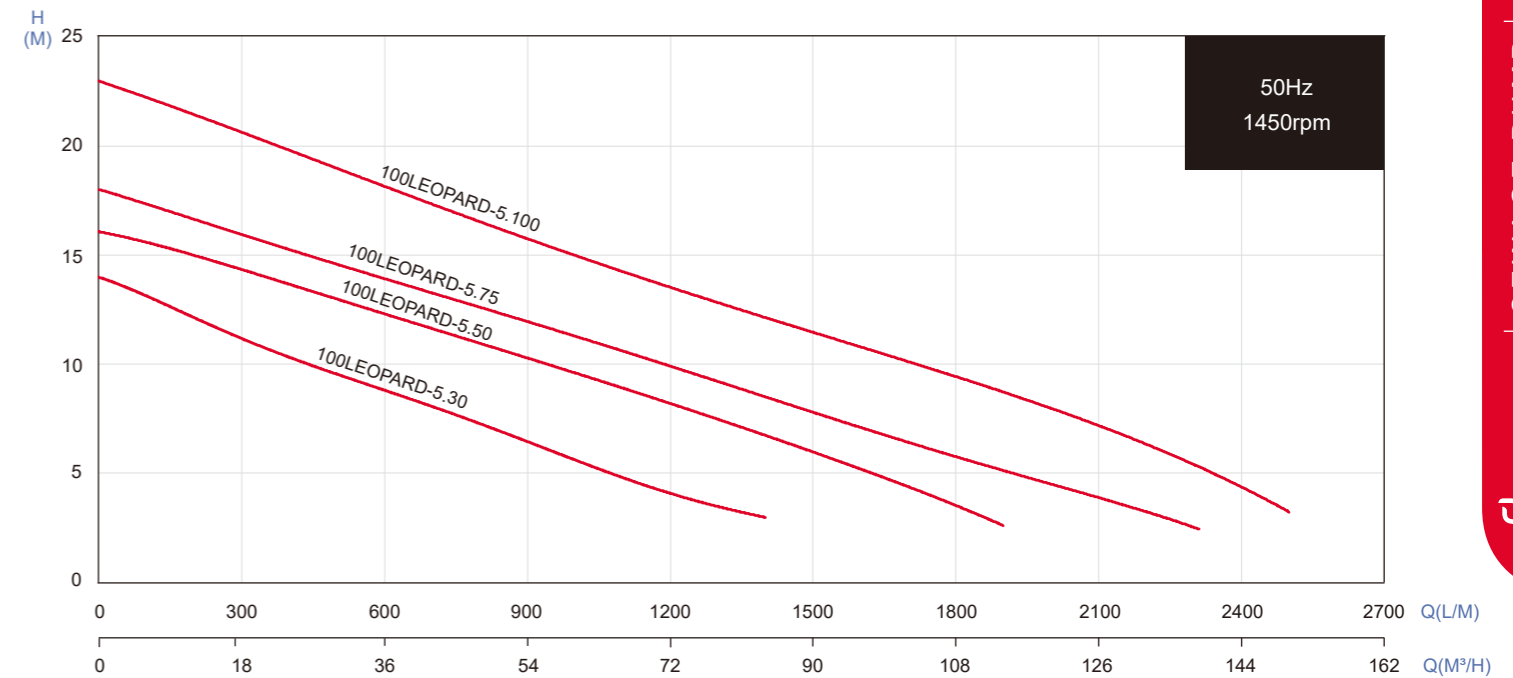

100LEOPARD-5.30~50

100LEOPARD-5.75~100

Dimensions (mm)

Type	A	A1	A2	A3	B	B1	B2	H	H1	H2	H3
80(100)LEOPARD-5.30	615	152	352	212	330	163	167	664	597	253	345
100LEOPARD-5.50	619	159	348	207	338	163	175	752	686	274	346
100LEOPARD-5.75	705	195	400	260	410	205	205	935	700	292	365
100LEOPARD-5.100	705	195	400	260	410	205	205	952	743	292	365