

**LIGHTWEIGHT SUBMERSIBLE DEWATERING PUMP**

**EUB**  
**EUBS AISI 304**  
**EUBI AISI 316**  
**SERIES 60HZ**



EUB WITH FLAP VALVE

**Features**

- High resistance to abrasive liquids
- Loss wax casting AISI 304 and AISI 316 for EUBS and EUBI
- Viton gasket, O-rings, and Lip seal for EUBI (AISI 316)
- Compact & Lightweight design
- Efficient circumferential cooling for continuous duty
- Low suction device with non-return flap valve, capable to keep the water within pump and pipe without much flowback

**Applications**

- Site drainage, mining, tunneling, public works, floods
- Cement industry, river intake, civil engineering projects
- Version "S" in AISI 304 and "I" in AISI 316 are suitable for light chemical liquids in drainage and general pumping applications

**Data Chart**

Type	Output		Discharge	F.L.A.			Rated		Maximum		Free Passage	Weight(W/O Cable)	
	HP	kW		1ø	3ø	3ø	Head	Cap.	Head	Cap.		mm	1ø-kg
			Inch	230V	230V	460V	FT	GPM	FT	GPM			
50EUB-6.05	0.5	0.37	2"	3.3A	2.2A	1.1A	26	30	33	61	6	11.3	11.3
50EUBS(I)-6.05	0.5	0.37	2"	3.3A	2.2A	1.1A	26	30	33	61	6	14.1(13.8)	14.1(13.8)
50EUB-6.10	1	0.75	2"	6A	4A	2A	33	55	62.4	82	6	13.7	13.7
50EUBS(I)-6.10	1	0.75	2"	6A	4A	2A	33	55	62.4	82	6	17.2(16.7)	17.2(16.7)
50(80)EUB-6.20	2	1.5	2"(3")	14A	8A	4A	43	70	62.5	132	6	21.1	21.1
50(80)EUBS-6.20	2	1.5	2"(3")	13A	8A	4A	43	80	62.5	153	6	25	25

» Float switch is optional for above pump in single phase.

**Specifications**

Liquid Temperature	0~40°C (32~104°F)	
Submersible depth	10M	
<b>Motor Part</b>	Frequency	60Hz
	Pole	2 Pole
	Type	Dry Type
	Insulation	Class B
	Protection	IP 68
	Protector	Auto-cut
<b>Pump Part</b>	Bearing	Ball Type
	Mechanical seal	Double Mechanical Seal
	Impeller	Semi-Open Impeller



**DU PONT Hytrel®**  
 Steel coated with thermoplastic polyester elastomer



Loss Wax Stainless Steel AISI 304 & 316 EUBS(I) Impeller



Viton gasket, O-rings, and Lip seal for EUBI (AISI 316)



FLAP VALVE

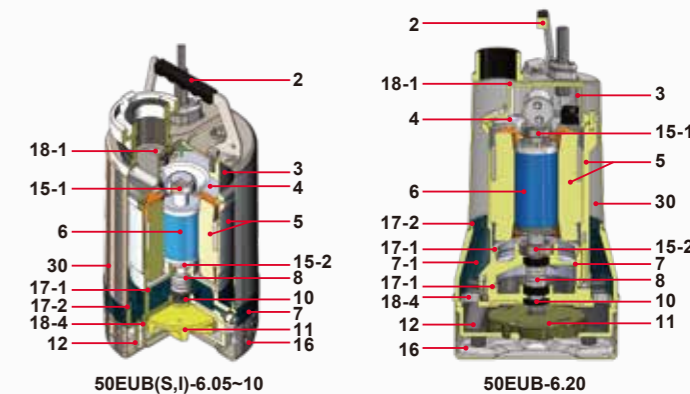

**Parts and Material List**

No.	Part	Material			
		EUB (0.5~1HP)	EUB (2HP)	EUBS	EUBI
2	Handle	Steel+BUNA N	Steel+BUNA N	AISI 304+BUNA N	AISI 304+BUNA N
3	Motor Cover	ADC12	ADC12	AISI 304	AISI 316
4	Bracket	Steel	Steel	ASTM A48 Class 30	ASTM A48 Class 30
5	Motor Housing + Stator	ADC12+Steel	ADC12+Steel	AISI 304	AISI 316
6	Shaft with Rotor	AISI 410	AISI 410	AISI 304	AISI 316
7	Oil Chamber	ADC12	ASTM A356	AISI 304	AISI 316
7-1	Oil Chamber	-	ASTM A356	-	-
8	Mechanical Seal	CA/CE+SIC/SIC			
10	Lip Seal	BUNA N	BUNA N	BUNA N	VITON
11	Impeller	Hytrel	Hytrel	AISI 304	AISI 316
12	Pump Casing	ASTM A48 Class 30	ASTM A48 Class 30	AISI 304	AISI 316
15-1	Upper Bearing	NTN/TPI			
15-2	Lower Bearing	NTN/TPI			
16	Strainer	AISI 304	AISI 304	AISI 304	AISI 316
17-1	O-ring	BUNA N	BUNA N	BUNA N	VITON
17-2	O-ring	BUNA N	BUNA N	BUNA N	VITON
18-1	Gasket	BUNA N	BUNA N	EPDM	VITON
18-4	Volute Liner	BUNA N	BUNA N	EPDM	EPDM
30	Outer Housing	AISI 304	AISI 304	AISI 304	AISI 316

TPI is a family brand of NTN group.

**Performance Curve**

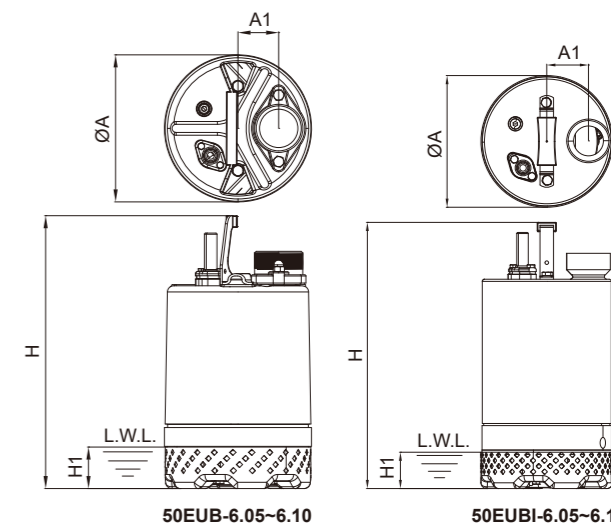
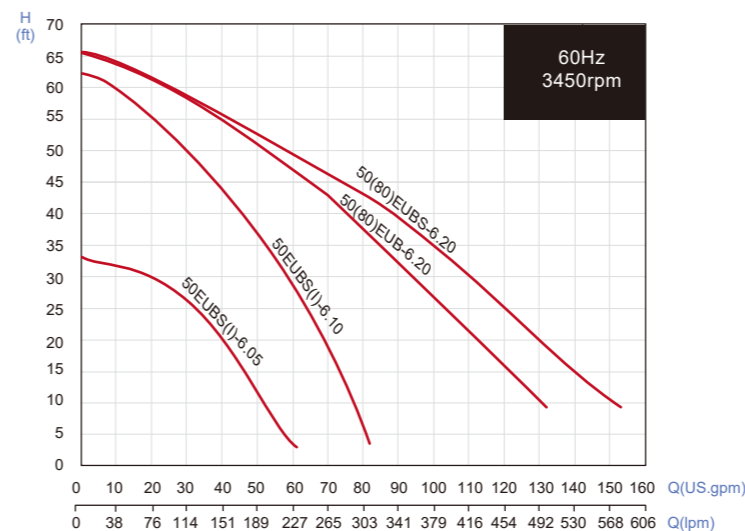

**Dimensions (mm)**

Type	A	A1	H	H1
50EUB-6.05	188	52	345	53
50EUBS(I)-6.05	188(184)	52	345	52
50EUB-6.10	188	52	370	53
50EUBS(I)-6.10	188(184)	52	370	52
50(80)EUB-6.20	225	52	474	81
50(80)EUBS-6.20	225	52	455	81