



SUBMERSIBLE GRINDER PUMP

ALLIGATOR

SERIES 50HZ



Grinder Ability



Features

- Robust construction
- Superior heat dissipation
- EKK Eagle Burgmann double mechanical seal CA/CE & SIC/SIC
- Semi-open impeller design prevents clogging by ground solids
- Radial grinder kit made in AISI 440C, corrosion resistant material and hardened to 55-60 HRC
- Specially designed high torque startup by centrifugal switch built-in for single phase motor
- Direct connect to pipe with horizontal discharge with inner thread
- Built-in Run/Start Capacitor(1 Phase only)

Specifications

Liquid Temperature		0~40°C (32~104°F)	
Submersible depth		10M	
Motor Part	Frequency	50Hz	
	Pole	2 Pole	
	Type	Dry Type	
	Insulation	1.5~3HP:Class B ; 5~7.5HP:Class F	
	Protection	IP 68	
Pump Part	Protector	Auto-Cut	
	Bearing	Ball Type	
	Mechanical seal	Double Mechanical Seal	
	Impeller	Semi-open Impeller	

Applications

- Wastewater treatment
- Sewage water
- Drainage of wastewater from individual residences, apartment buildings, recreational developments, motels.
- Transferring wastewater, schools, federal, state and local parks
- To transfer various wastewater and sewage

Data Chart

Type	Output		Discharge	F.L.A.		Rated		Maximum		Weight(W/O Cable)	
	HP	kW		1ø	3ø	Head M	Cap. LPM	Head M	Cap. LPM	1ø-kg	3ø-kg
32ALLIGATOR-5.15	1.5	1.1	1-1/4"	9.4A	3.3A	15.5	90	21	160	29.4	29.4
32ALLIGATOR-5.20	2	1.5	1-1/4"	11.5A	4.5A	23	100	28.5	160	32	32
32ALLIGATOR-5.30	3	2.2	1-1/4"	-	4.7A	25	120	31	160	-	33.6
50ALLIGATOR-5.50	5	3.7	2"	-	8.7A	26	250	37	300	-	41.2
50ALLIGATOR-5.75	7.5	5.5	2"	-	12.5A	36	250	46	300	-	46.2

» QG Guide rail systems for easy-out/easy-in plumbing is optional for 1.5~7.5HP.
 » All single-phase pumps can be equipped with float switch upon request.

Section View

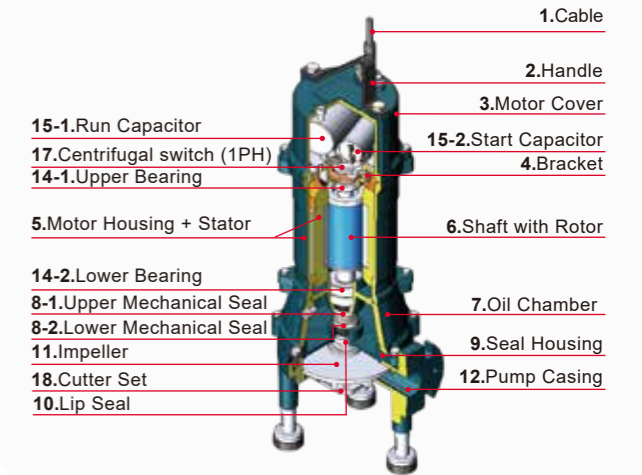

Performance Curve

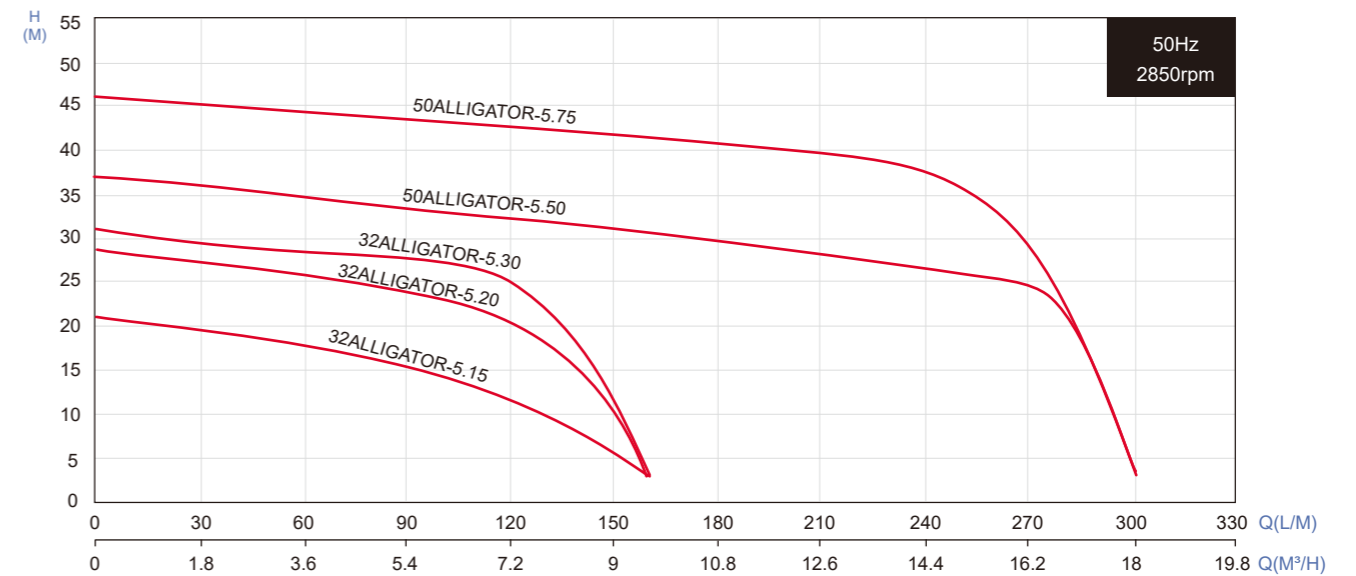

All technical information is subject to change without notice.

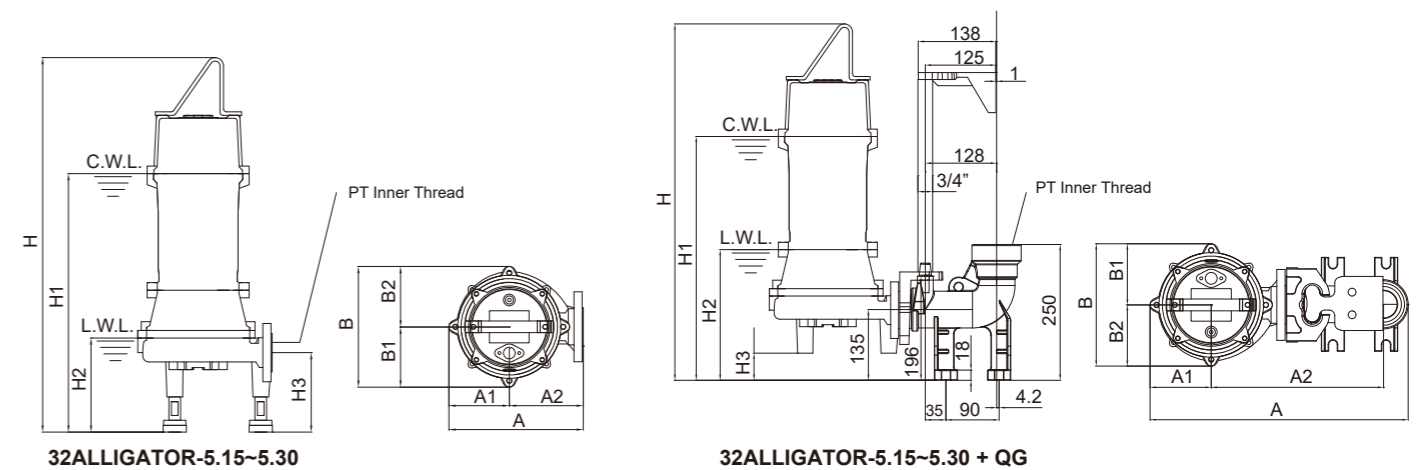

Dimensions (mm)

Type	A	A1	A2	B	B1	B2	H	H1	H2	H3
32ALLIGATOR-5.15(QG)	230(445)	102	128(300)	206	103	103	640(630)	445(432)	160(150)	135(50)
32ALLIGATOR-5.20(QG)	230(445)	102	128(300)	206	103	103	640(630)	445(432)	160(150)	135(50)
32ALLIGATOR-5.30(QG)	230(445)	102	128(300)	206	103	103	680(670)	485(472)	160(150)	135(50)
50ALLIGATOR-5.50(QG)	283(500)	119	164(337.3)	239	114	125	669(637)	509(477)	186(154)	151(29)
50ALLIGATOR-5.75(QG)	283(500)	119	164(337.3)	239	114	125	709(677)	549(517)	186(154)	151(29)

» (QG) identifies ALLIGATOR pump with QG Q.D.C.